

RoHS
Compliant

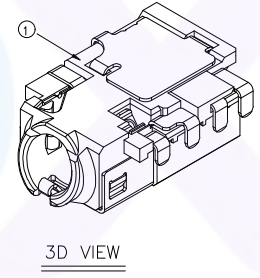

- NOTES:
1. MATERIAL: SEE "TABLE 1";
 2. FINISH: SEE "TABLE 1";
 3. ELECTRICAL:
 - 3.1. VOLTAGE RATING: 12 VAC RMS;
 - 3.2. CURRENT RATING: 0.5 AMP;
 - 3.3. CONTACT RESISTANCE: 50mΩ Max.(Initial), 100mΩ Max.(After Life test);
 - 3.4. INSULATION RESISTANCE: 1000 MΩ Min., 500VDC.(Initial), 100 MΩ Min., 500VDC.(After Humidity test);
 - 3.5. WITHSTAND VOLTAGE: 500 VAC RMS 50(60)Hz, 1 minute;
 4. MECHANICAL:
 - 4.1. MATING FORCE: 3.0Kgf MAX.;
 - 4.2. UNMATING FORCE: 0.3Kgf MIN.;
 - 4.3. OPERATING LIFE: 5000 CYCLES MIN.;
 5. ENVIRONMENTAL:
 - 5.1. OPERATION: -30°C~+80°C.

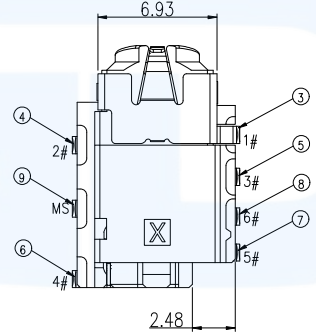
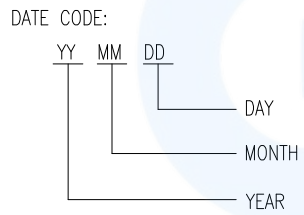
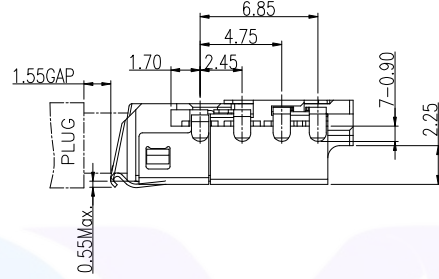
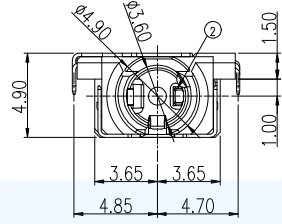
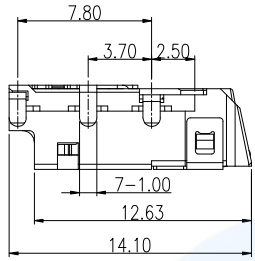
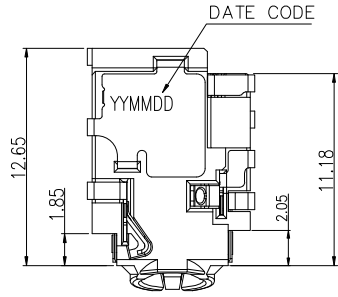
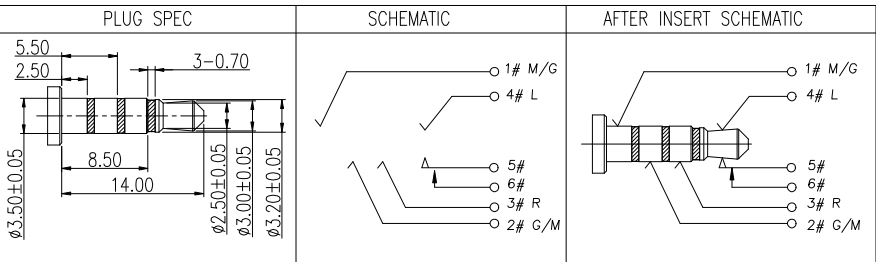
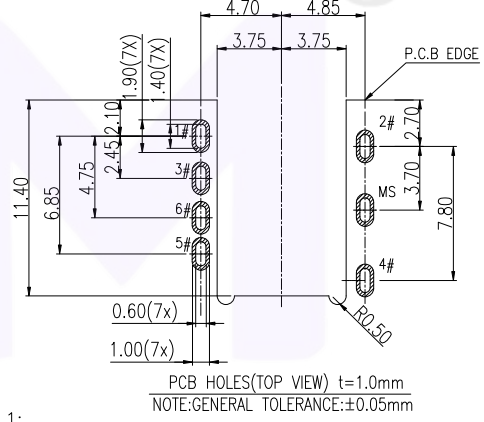

TABLE 1:

| NO. | PART NAME | QTY | MATERIAL | DESCRIPTION | REMARK |
|-----|-----------|-----|--------------|--|----------|
| ① | Shell | 1 | Copper Alloy | Ni 50u" Min. | T=0.20mm |
| ② | Contact_6 | ⑤ | Copper Alloy | CONTACT AREA: 1U"MIN SOLDER AREA:G/F 50u" OVER ALL | T=0.20mm |
| ③ | Contact_5 | ⑤ | Copper Alloy | | T=0.20mm |
| ④ | Contact_4 | ④ | Copper Alloy | | T=0.20mm |
| ⑤ | Contact_3 | ③ | Copper Alloy | | T=0.20mm |
| ⑥ | Contact_2 | ② | Copper Alloy | | T=0.20mm |
| ⑦ | Contact_1 | ① | Copper Alloy | | T=0.20mm |
| ⑧ | Separator | 1 | HIGH TEMP | BLACK,UL94V-0 | |
| ⑨ | Housing | 1 | HIGH TEMP | BLACK,UL94V-0 | |

广东小迈实业有限公司

Website: <https://www.xmconn.com> TEL: 18938295888



PART NAME: Ø3.5mm Phone Jack CONN.
PART NO.: DM35A019-07FP

TOLERANCE UNLESS OTHERWISE SPECIFIED:
X ±0.2
X.X ±0.15
X.XX ±0.10
X.XXX ±0.050

| | | | | | | | |
|-----------|------|-------|------------|--------|--------|-------|----|
| DRAWING: | Li | DATE: | 2023.08.18 | SCALE: | SHEET: | REV: | A0 |
| CHECK: | Chen | DATE: | 2023.08.18 | 1:1 | 1/2 | SIZE: | A4 |
| APPROVAL: | Wen | DATE: | 2023.08.18 | | | | |

RoHS
Compliant

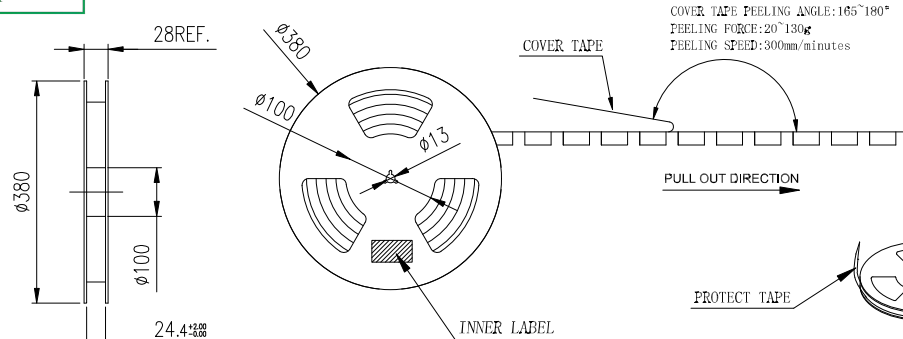

COVER TAPE PEELING ANGLE:165~190°
PEELING FORCE:20~130g
PEELING SPEED:300mm/minutes

PULL OUT DIRECTION

PROTECT TAPE

10 DISK

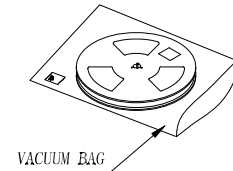

VACUUM BAG

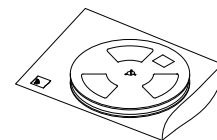

DRYER

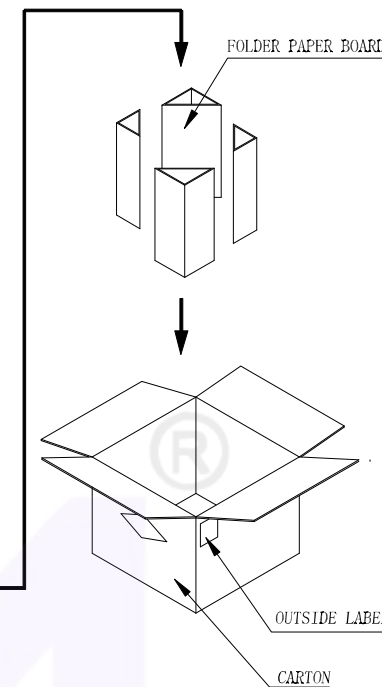
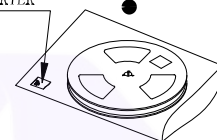

FOLDER PAPER BOARD

OUTSIDE LABEL

CARTON

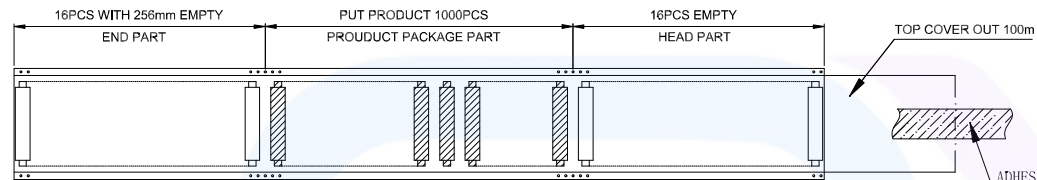

PULL OUT DIRECTION

NOTES:

1. Material requirements:

- 1.1 The carton material requirements for the K=A. Dimension is 400*400*300mm;
- 1.2 Reel materials for PET; size reel for 380*28.4.

2. Packaging requirements:

- 2.1 The tape into the packing machine, before the empty 16PCS, after the release of the product 1000PCS, then the empty 16PCS with 256mm length of stay;
- 2.2 Top cover should out 100mm of the carrier tape. After winding, using adhesive tape (80-150mm) to stick the leader of cover tap on the side of the carrier tape;
- 2.3 Winding a protect tape around the reel, then stick it by adhesive tape;
- 2.4 label should paste in the designated area of the reel;
- 2.5 Put a dryer and a packed reel in the vacuum bag and make the vacuum process;
- 2.6 The tired folded 10 disks in the carton total 10000pcs;
- 2.7 Packed finished packing sealing, and in the outer carton label

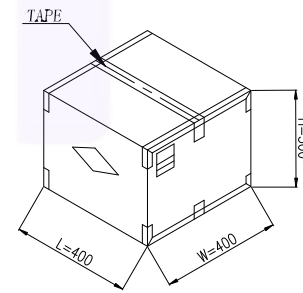
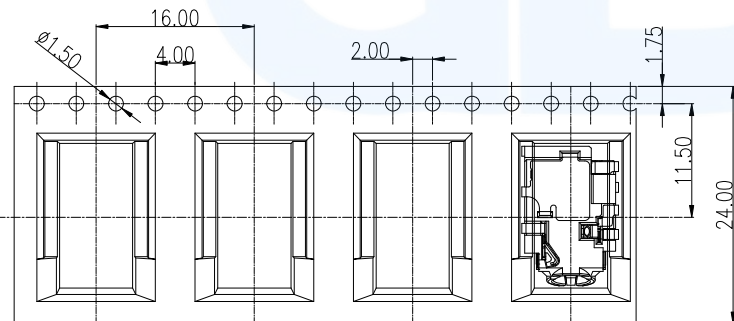

CARTON SIZE

1 CARTON = 10 REEL = 10000 PRODUCT

广东小迈实业有限公司

Website:

<https://www.xmconn.com>

TEL:

18938295888



PART NAME

ø3.5mm Phone Jack CONN.

PART NO.

DM35A019-07FP

TOLERANCE UNLESS OTHERWISE SPECIFIED:

X ±0.2
X.X ±0.15
X.XX ±0.10
X.XXX ±0.050

DRAWING:

Li

DATE:

2023.08.18

SCALE

SHEET

REV: A0

CHECK:

Chen

DATE:

2023.08.18

1:1

2/2

SIZE: A4

APPROVAL:

Wen

DATE:

2023.08.18

