

RoHS
Compliant

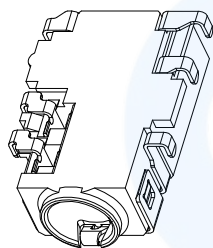

3D VIEW

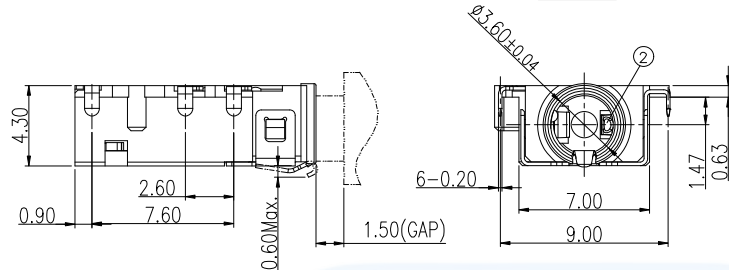
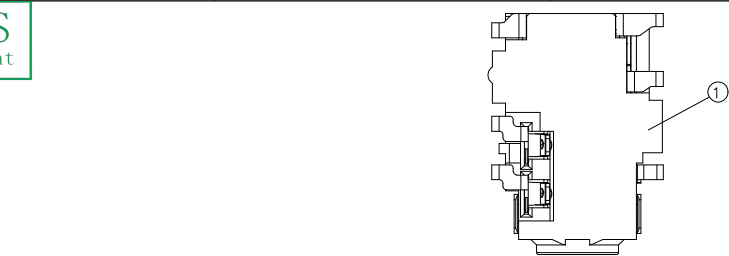
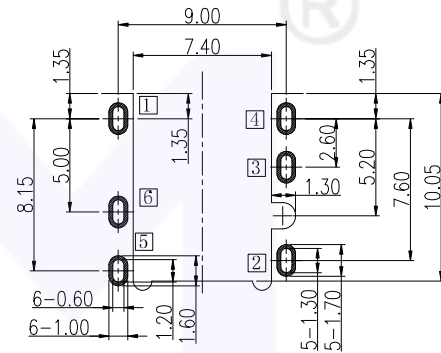
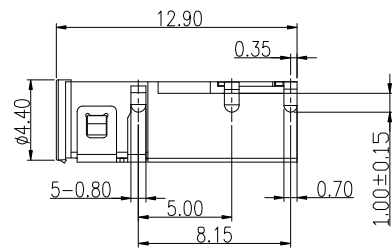
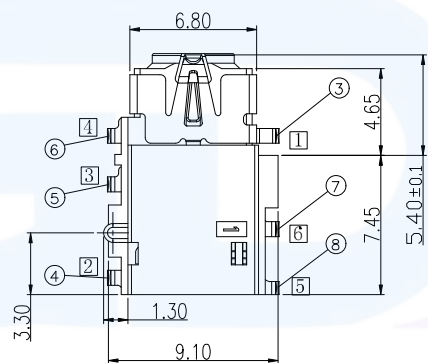

TOP VIEW (TOLRANCE:±0.05)

NOTES:

1. MATERIAL: SEE "TABLE 1";
2. FINISH: SEE "TABLE 1";
3. ELECTRICAL:
 - 3.1. VOLTAGE RATING: 12 VAC RMS;
 - 3.2. CURRENT RATING: 1 AMP;
 - 3.3. CONTACT RESISTANCE: 50mΩ Max.(Initial), 100mΩ Max.(After Life test);
 - 3.4. INSULATION RESISTANCE: 100 MΩ Min., 500VDC.(Initial), 50 MΩ Min., 500VDC.(After Humidity test);
 - 3.5. WITHSTAND VOLTAGE: 500 VAC RMS 50(60)Hz, 1 minute;
4. MECHANICAL:
 - 4.1. MATING FORCE: 0.3-3.0Kgf.
 - 4.2. UNMATING FORCE: 0.3-3.0Kgf.
 - 4.3. OPERATING LIFE: 5000 CYCLES MIN.;
5. ENVIRONMENTAL:
 - 5.1. SALT SPRAY: 48H.
 - 5.2. OPERATION: -30°C~+80°C.

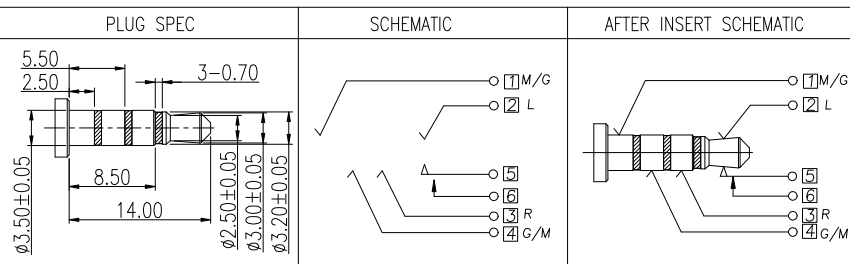

TABLE 1:

NO.	PART NAME	QTY	MATERIAL	DESCRIPTION	REMARK
⑧	Contact_5	1	Phosphor bronze	Au 1u"Min	T=0.20mm
⑦	Contact_6	1	Phosphor bronze	Au 1u"Min	T=0.20mm
⑥	Contact_4	1	Phosphor bronze	Au 1u"Min	T=0.20mm
⑤	Contact_3	1	Phosphor bronze	Au 1u"Min	T=0.20mm
④	Contact_2	1	Phosphor bronze	Au 1u"Min	T=0.20mm
③	Contact_1	1	Phosphor bronze	Au 1u"Min	T=0.20mm
②	Separator	1	HIGH TEMP. PLASTIC	Black	
①	Housing	1	HIGH TEMP. PLASTIC	Black	

广东小迈实业有限公司

Website: <https://www.xmconn.com> TEL: 18938295888



PART NAME	ø3.5mm Phone Jack CONN.
PART NO.	DM35A016-06FP

TOLERANCE UNLESS OTHERWISE SPECIFIED:
 X ±0.2
 X.X ±0.15
 X.XX ±0.10
 X.XXX ±0.050

DRAWING:	Li	DATE:	2023.09.18	SCALE	SHEET	REV: A0
CHECK:	Chen	DATE:	2023.09.18	1:1	1/2	SIZE: A4
APPROVAL:	Yuan	DATE:	2023.09.18			

RoHS
Compliant

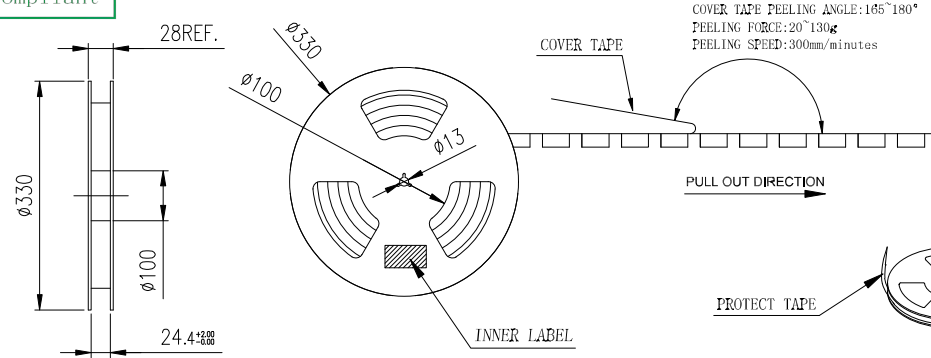

COVER TAPE PEELING ANGLE:165°~180°
PEELING FORCE:20~130g
PEELING SPEED:300mm/minutes

PULL OUT DIRECTION

PROTECT TAPE

10 DISK

VACUUM BAG

DRYER

FOLDER PAPER BOARD

OUTSIDE LABEL

CARTON

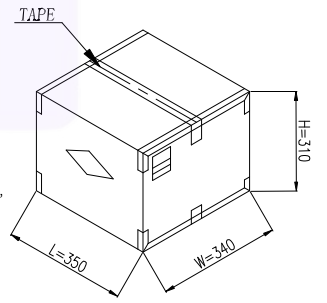

CARTON SIZE

1 CARTON = 10 REEL = 8000 PRODUCT

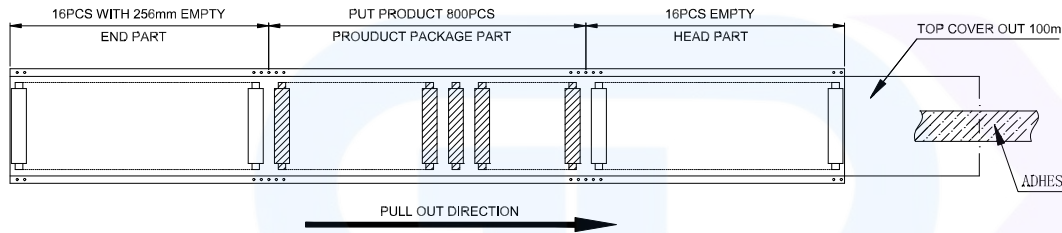

PULL OUT DIRECTION

NOTES:

1. Material requirements:

- 1.1 The carton material requirements for the B=B, Dimension is 350*340*310mm;
- 1.2 Reel materials for PS; size reel for 330*28.

2. Packaging requirements:

- 2.1 The tape into the packing machine, before the empty 16PCS, after the release of the product 800PCS, then the empty 16PCS with 256mm length of stay;
- 2.2 Top cover should out 100mm of the carrier tape. After winding, using adhesive tape (80~150mm) to stick the leader of cover tap on the side of the carrier tape;
- 2.3 Winding a protect tape around the reel, then stick it by adhesive tape;
- 2.4 Label should paste in the designated area of the reel;
- 2.5 Put a dryer and a packed reel in the vacuum bag and make the vacuum process;
- 2.6 The tired folded 10 disks in the carton total 8000pcs;
- 2.7 Packed finished packing sealing, and in the outer carton label

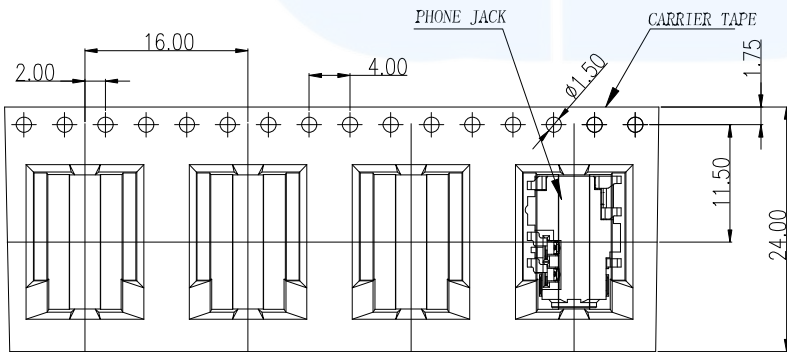

广东小迈实业有限公司

Website:

<https://www.xmconn.com>

TEL:

18938295888



PART NAME

φ3.5mm Phone Jack CONN.

PART NO.

DM35A016-06FP

TOLERANCE UNLESS OTHERWISE SPECIFIED:

X ±0.2
X.X ±0.15
X.XX ±0.10
X.XXX ±0.050

DRAWING:

Li

DATE:

2023.09.18

SCALE

SHEET

REV: A0

CHECK:

Chen

DATE:

2023.09.18

1:1

2/2

SIZE: A4

APPROVAL:

Yuan

DATE:

2023.09.18

