

RoHS
Compliant

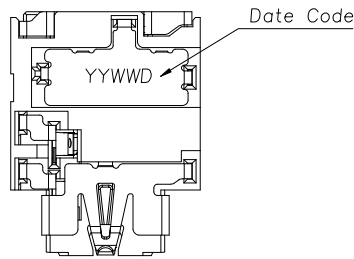

NOTES:

1. MATERIAL: SEE "TABLE 1";
2. FINISH: SEE "TABLE 1";
3. ELECTRICAL:
 - 3.1. VOLTAGE RATING: 12 VAC RMS;
 - 3.2. CURRENT RATING: 0.5 AMP;
 - 3.3. CONTACT RESISTANCE: 50mΩ Max.(Initial),
100mΩ Max.(After Life test);
 - 3.4. INSULATION RESISTANCE: 1000 MΩ Min., 500VDC.(Initial),
100 MΩ Min., 500VDC.(After Humidity test);
 - 3.5. WITHSTAND VOLTAGE: 500 VAC RMS 50(60)Hz, 1 minute;
4. MECHANICAL:
 - 4.1. MATING FORCE: 3.0kgf MAX.;
 - 4.2. UNMATING FORCE: 0.3kgf MIN.;
 - 4.3. OPERATING LIFE: 5000 CYCLES MIN.;
5. ENVIRONMENTAL:
 - 5.1. OPERATION: -30°C~+80°C.

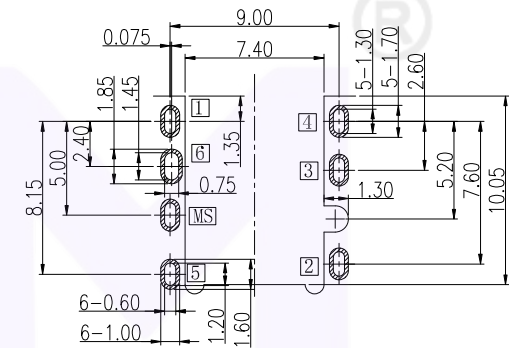
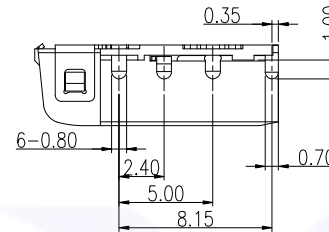
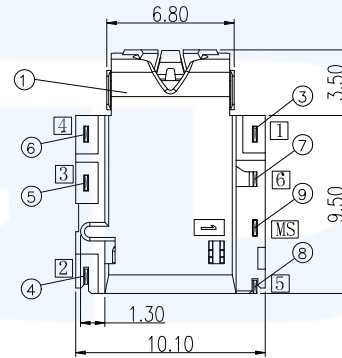
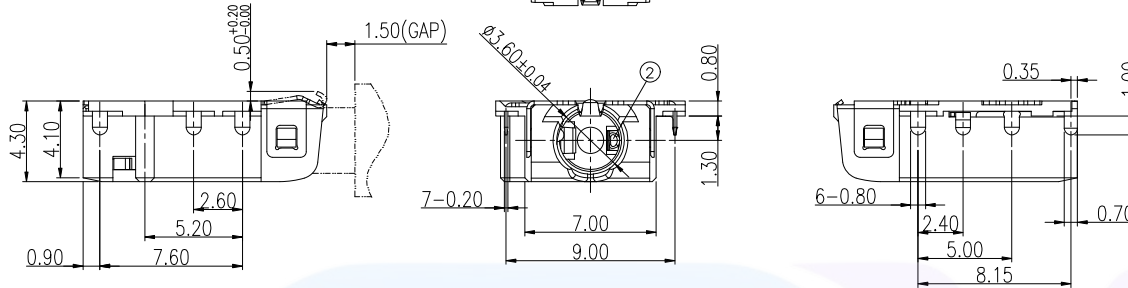

RECOMMENDED P.C.B LAYOUT
TOP VIEW (TOLRANCE:±0.05)

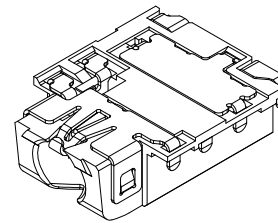
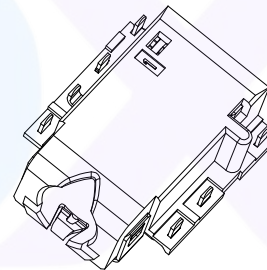

3D VIEW

PLUG SPEC	SCHEMATIC	AFTER INSERT SCHEMATIC

TABLE 1:

NO.	PART NAME	QTY	MATERIAL	DESCRIPTION	REMARK
⑨	Shell	1	Stainless steel	Ni 50u" Min	T=0.20mm
⑧	Contact_5	⑤	Phosphor bronze	g/F On Contact And Solder Tail Area,	T=0.20mm
⑦	Contact_6	⑥	Phosphor bronze		T=0.20mm
⑥	Contact_4	④	Phosphor bronze	Gold Flash on contact area, Plate Matte Tin on solder tail, Nickel underplated.	T=0.20mm
⑤	Contact_3	③	Phosphor bronze		T=0.20mm
④	Contact_2	②	Phosphor bronze		T=0.20mm
③	Contact_1	①	Phosphor bronze		T=0.20mm
②	Separator	1	HIGH TEMP	BLACK,UL94V-0	
①	Housing	1	HIGH TEMP	BLACK,UL94V-0	

广东小迈实业有限公司

Website:

<https://www.xmconn.com>

TEL:

18938295888



PART NAME ϕ3.5mm Phone Jack CONN.

PART NO. DM35A014-07FP

TOLERANCE UNLESS OTHERWISE SPECIFIED:

- X ±0.2
- X.X ±0.15
- X.XX ±0.10
- X.XXX ±0.050

DRAWING:

Li

DATE: 2023.09.18

SCALE

SHEET

REV: A0

CHECK:

Chen

DATE: 2023.09.18

1:1

1/2

SIZE: A4

APPROVAL:

Yuan

DATE: 2023.09.18



F

E

D

C

B

A

RoHS
Compliant

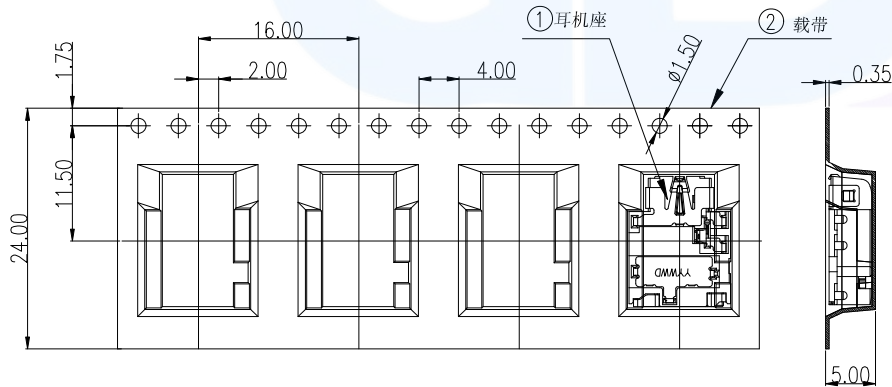
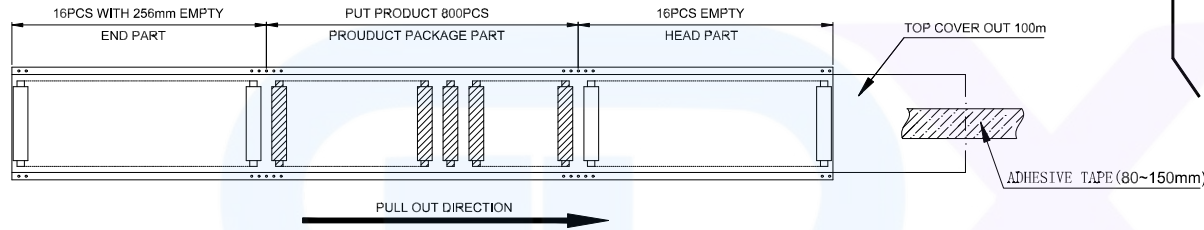
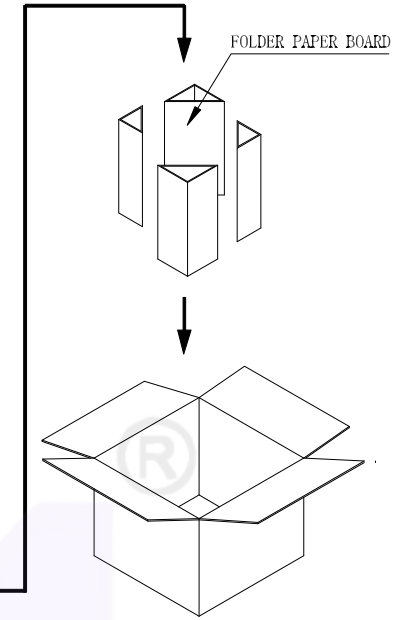
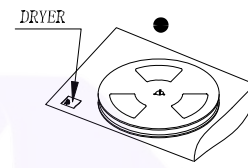
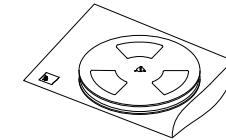
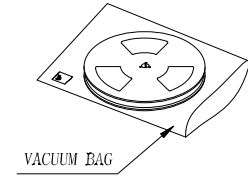
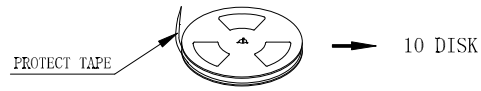
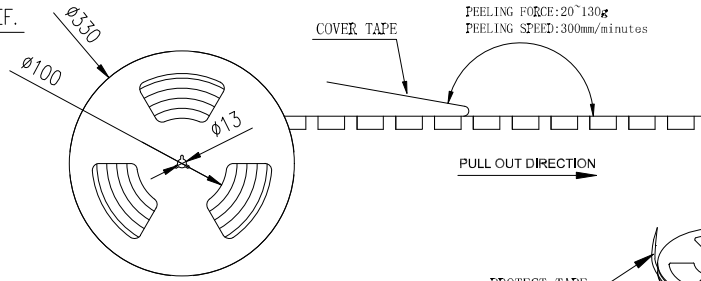
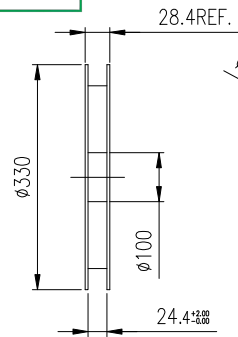

NOTES:

1. Material requirements:
 - 1.1 The carton material requirements for the K=A, Dimension is 350*340*310mm;
 - 1.2 Reel materials for PET; size reel for 330*28.4.
2. Packaging requirements:
 - 2.1 The tape into the packing machine, before the empty 16PCS, after the release of the product 800PCS, then the empty 16PCS with 256mm length of stay;
 - 2.2 Top cover should out 100mm of the carrier tape. After winding, using adhesive tape (80~150mm) to stick the leader of cover tap on the side of the carrier tape;
 - 2.3 Winding a protect tape around the reel, then stick it by adhesive tape;
 - 2.4 Label should paste in the designated area of the reel;
 - 2.5 Put a dryer and a packed reel in the vacuum bag and make the vacuum process;
 - 2.6 The tired folded 10 disks in the carton total 8000pcs;
 - 2.7 Packed finished packing sealing, and in the outer carton label

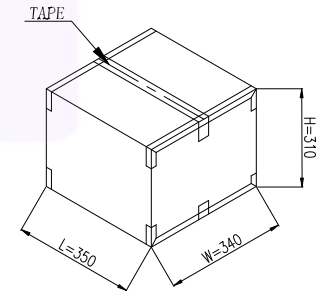

CARTON SIZE

1 CARTON = 10 REEL = 8000 PRODUCT

广东小迈实业有限公司

Website:

<https://www.xmconn.com>

TEL:

18938295888



PART NAME ϕ 3.5mm Phone Jack CONN.

PART NO. DM35A014-07FP

TOLERANCE UNLESS OTHERWISE SPECIFIED:

X \pm 0.2
X.X \pm 0.15
X.XX \pm 0.10
X.XXX \pm 0.050

DRAWING:

Li

DATE:

2023.09.18

CHECK:

Chen

DATE:

2023.09.18

APPROVAL:

Yuan

DATE:

2023.09.18

SCALE

1:1

SHEET

2/2

REV: A0

SIZE: A4

