

RoHS
Compliant

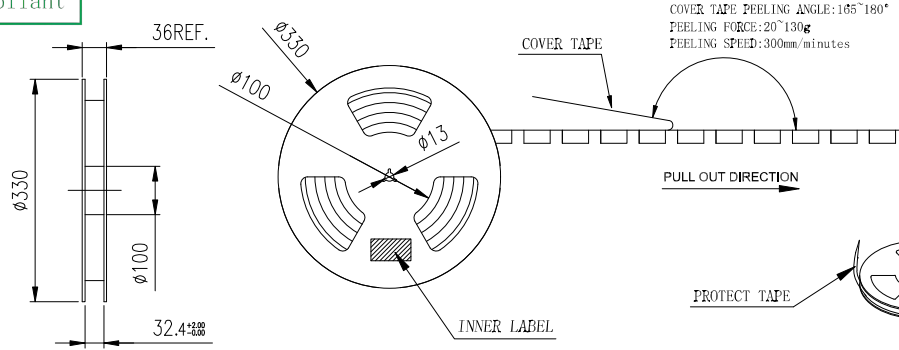

COVER TAPE PEELING ANGLE:165°-180°
PEELING FORCE:20~130g
PEELING SPEED:300mm/minutes

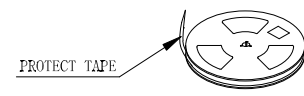

8 DISK

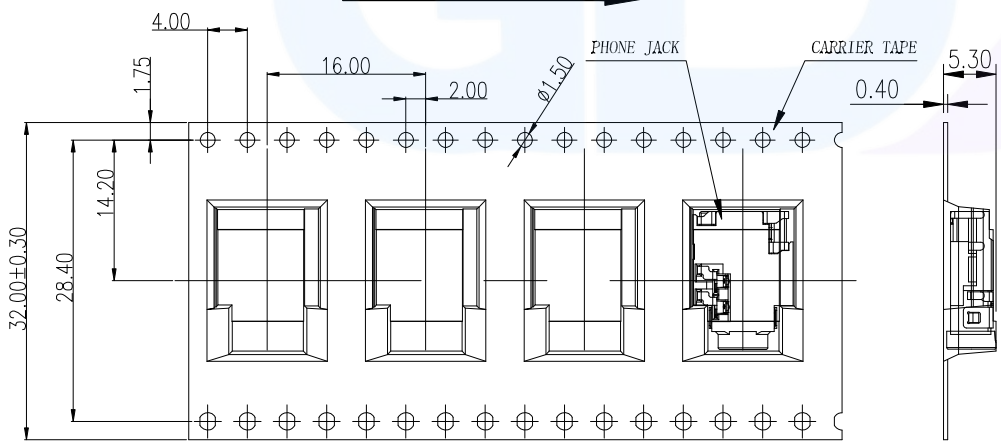
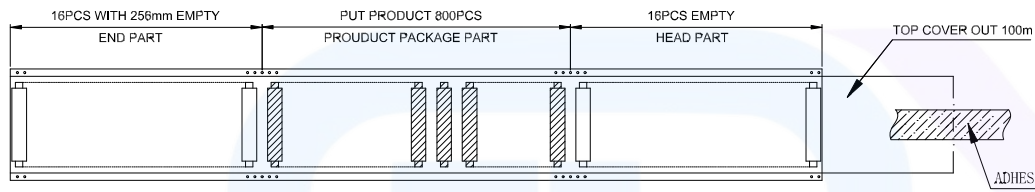
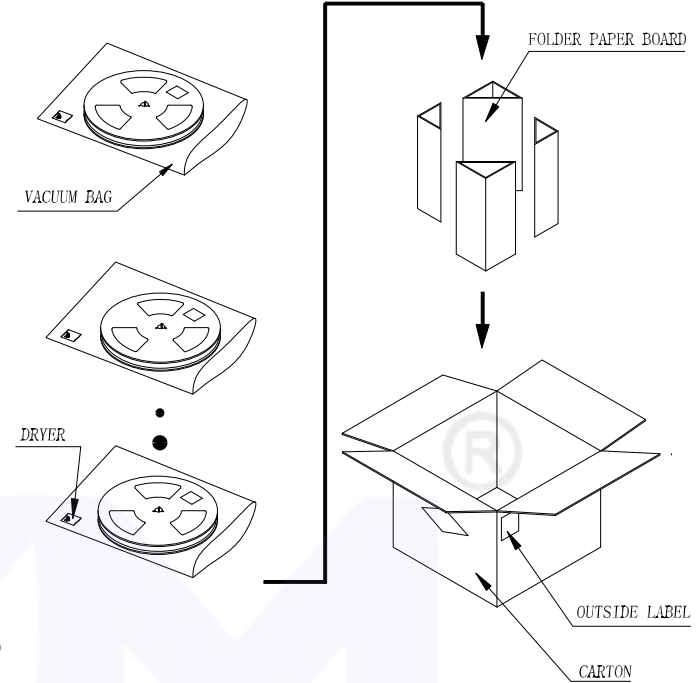

NOTES:

- Material requirements:
 - The carton material requirements for the B-B, Dimension is 350*340*310mm;
 - Reel materials for PS; size reel for 330*36.
- Packing requirements:
 - The tape into the packing machine, before the empty 16PCS, after the release of the product 800PCS, then the empty 16PCS with 256mm length of stay;
 - Top cover should out 100mm of the carrier tape. After winding, using adhesive tape (80-150mm) to stick the leader of cover tap on the side of the carrier tape;
 - Winding a protect tape arround the reel, then stick it by adhesive tape;
 - label should paste in the designated area of the reel;
 - Put a dryer and a packed reel in the vacuum process;
 - The tired folded 8 disks in the carton total 6400pcs;
 - Packed finished packing sealing, and in the outer carton label

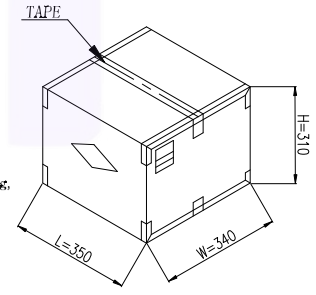

CARTON SIZE

1 CARTON = 8 REEL = 6400 PRODUCT

广东小迈实业有限公司

Website: <https://www.xmconn.com> TEL: 18938295888



PART NAME	φ3.5mm Phone Jack CONN.
PART NO.	DM35A012-06FP

TOLERANCE UNLESS OTHERWISE SPECIFIED:	
X	±0.2
X.X	±0.15
X.XX	±0.10
X.XXX	±0.050

DRAWING:	Li	DATE:	2023.09.18	SCALE	SHEET	REV: A0
CHECK:	Chen	DATE:	2023.09.18	1:1	2/2	SIZE: A4
APPROVAL:	Yuan	DATE:	2023.09.18			