

RoHS
Compliant

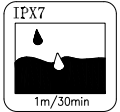

SPECIFICATIONS:

- 1.RATING: 12V, 1A .
- 2.CONTACT RESISTANCE:30mΩ OR LESSFOR INITIAL
- 3.VOLTAGE PROOF:500V AC FOR ONE MINUTE
- 4.DURABILITY:5,000 INSERTION/EXTRACTION CYCLES
- 5.INSETION FORCE:3.0KG MAX
- 6.WITHDRAWAL FORCE:0.3KG MIN
- 7.WATER PROOFNESS: THIS PRODUCT IS BASED ON IPX7(1m,30min)
- 8.USING PLUG: φ3.5MM、3-POLE STEREO
9. OVAL RING
 - 9-1. Hardness of silicone rubber:70°
 - 9-2. Horizontal flash 0.10mm max;Longitudinal flash 0.10mm max
- 10.HOUSING WITH O-RING'S SEAL AREA BURRS IS 0.05mm MAX.
- 11.FOR REFLOW SOLDERING LEAD-FREE PROCESS.
- 12.PACKAGING: TAPE & REEL.

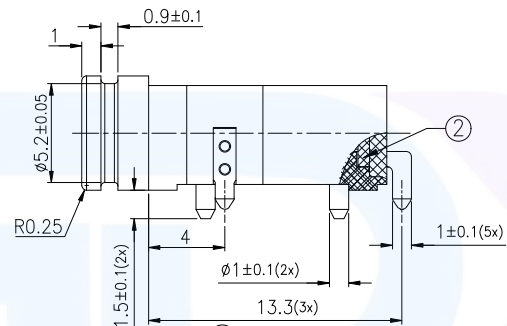
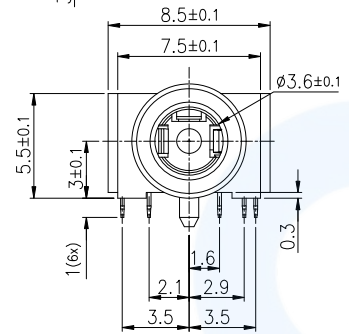
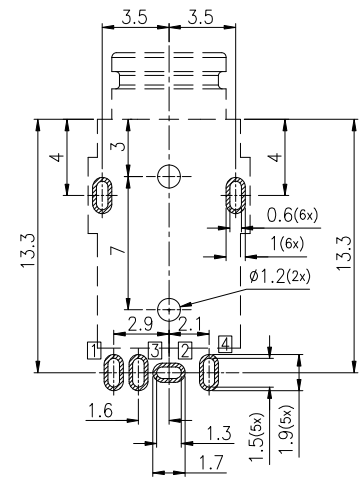
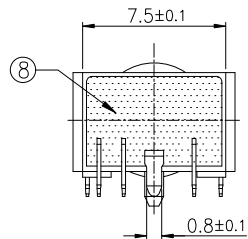
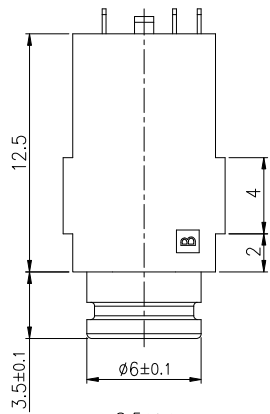

Recommended PCB Layout(T=1.2)
Tolerance: ±0.05(TOP view)

UNLESS OTHERWISE SPECIFIED, TOLERANCE ON DECIMAL: ±0.2

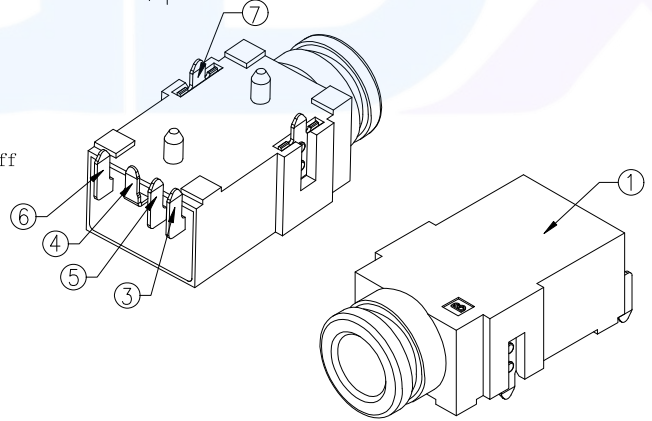
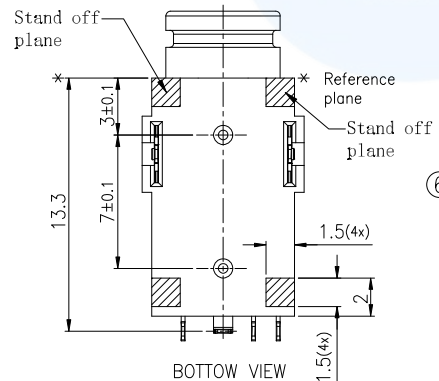
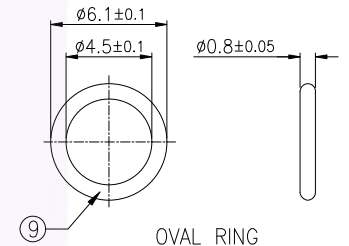
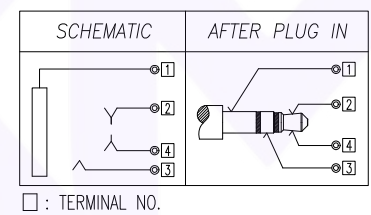

ITEM	PART NAME	TERMINAL	QTY	MATERIAL	REMARK
9	OVAL RING	----	1	SILICONE	GREEN
8	BOND	----	1	EPOXY	----
7	TERMINAL	----	2	C2680R-H T=0.2	Matte Sn 80u" Min; Ni 40u" Min underplate
6	TIP SPRING-2	4	1	C5210R-EH T=0.2	
5	RING SPRING	3	1	C5210R-EH T=0.2	
4	TIP SPRING-1	2	1	C5210R-EH T=0.2	
3	EARTH SPRING	1	1	C5210R-EH T=0.2	
2	COVER	----	1	PA9T+33%GF(GN2330)	UL 94V-0
1	HOUSING	----	1	PA9T+33%GF(GN2330)	UL 94V-0

广东小迈实业有限公司

Website: <https://www.xmconn.com> TEL: 18938295888



PART NAME	φ3.5mm WATERPROOF JACK
PART NO.	DM35A007-07DP

TOLERANCE UNLESS OTHERWISE SPECIFIED:
X ±0.2
X.X ±0.15
X.XX ±0.10
X.XXX ±0.050

DRAWING:	Li	DATE:	2023.08.18	SCALE	SHEET	REV:	A0
CHECK:	Chen	DATE:	2023.08.18	1:1	1/1	SIZE:	A4
APPROVAL:	Wen	DATE:	2023.08.18				