

RoHS
Compliant

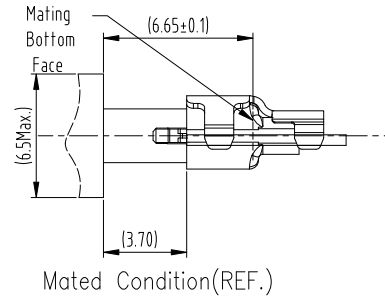

- NOTES:
SPECIFICATION:
1. CURRENT RATING: 3.0A MAX
 2. VOLTAGE: 100 VAC
 3. TEMPERATURE RANGE: -30 °C ~ 85 °C
 4. CONTACT RESISTANCE: 40 MILLIONHM MAX
 5. INSULATION RESISTANCE: 100 MEGOHMS MIN.
 6. INSERTION FORCE : 5N~20N
 7. UNMATING FORCE: 8N~20N
 8. DURABILITY: 10,000 CYCLES

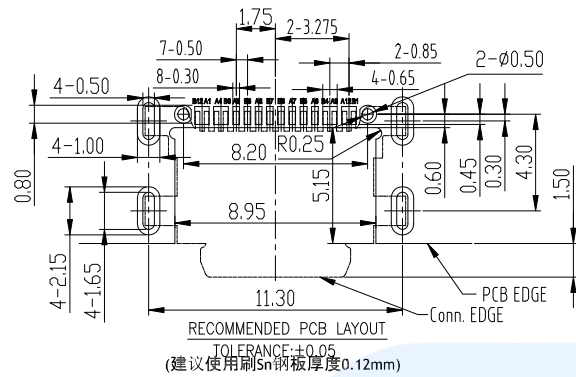
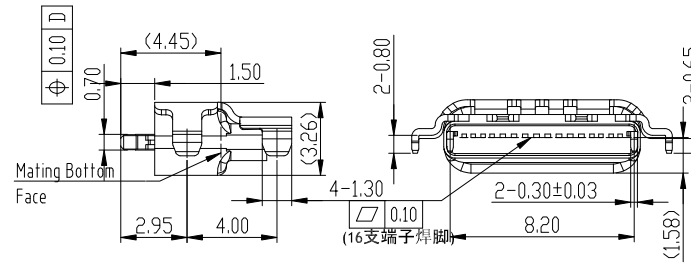
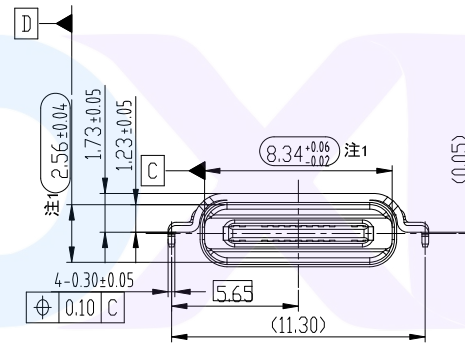
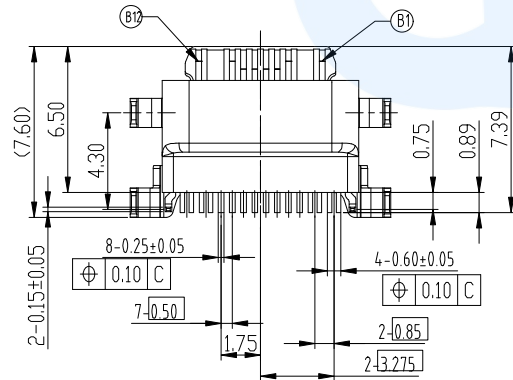
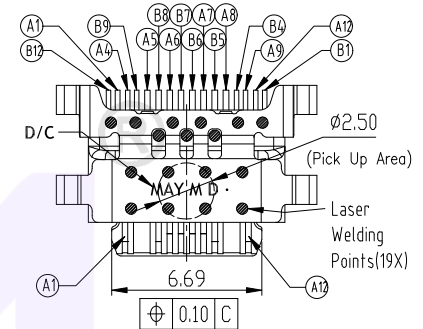

Pin Assignments

Contact Number	Signal Name	Contact Number	Signal Name
A1	GND	B12	GND
A4	VBUS	B9	VBUS
A5	CC1	B8	SBU2
A6	Dp1	B7	Dn2
A7	Dn1	B6	Dp2
A8	SBU1	B5	CC2
A9	VBUS	B4	VBUS
A12	GND	B1	GND

NO.	DESCRIPTION	MATERIAL	REMARKS	QTY
8	TOP SHELL	STAINLESS STEEL	Ti/Ni Plated	1PCS
7	SHELL	STAINLESS STEEL	Ni Plated	1PCS
6	OVER MOLDING	HIGH TEMPERATURE PLASTIC	BLACK	1PCS
5	TOP I/M	HIGH TEMPERATURE PLASTIC	BLACK	1PCS
4	BOTTOM I/M	HIGH TEMPERATURE PLASTIC	BLACK	1PCS
3	MID PLATE	STAINLESS STEEL	Ti/Ni Plated	1PCS
2	CONTACT	COPPER ALLOY	Au/Ni Plated	1SET
1	CONTACT	COPPER ALLOY	Au/Ni Plated	1SET

注1: "○"表示CPK尺寸

广东小迈实业有限公司

Website:

<https://www.xmconn.com>

TEL:

18938295888



PART NAME

USB Type-C 16pin 沉板1.58 舌片外露1.5防水型成品

PART NO.

DM68010-16FBAP-A

TOLERANCE UNLESS OTHERWISE SPECIFIED:

X ±0.2
X.X ±0.15
X.XX ±0.10
X.XXX ±0.050

DRAWING:

Li

DATE:

2023.08.18

SCALE

SHEET

REV: A0

CHECK:

Chen

DATE:

2023.08.18

1:1

1/1

SIZE: A4

APPROVAL:

Wen

DATE:

2023.08.18



RoHS
Compliant

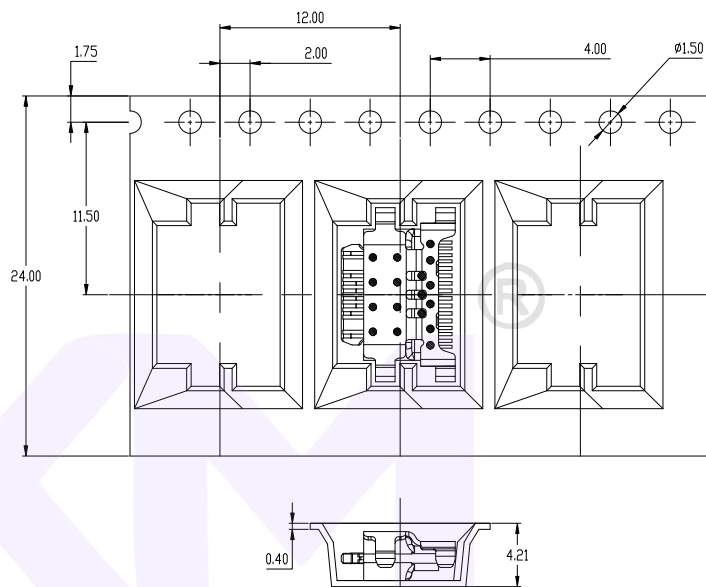
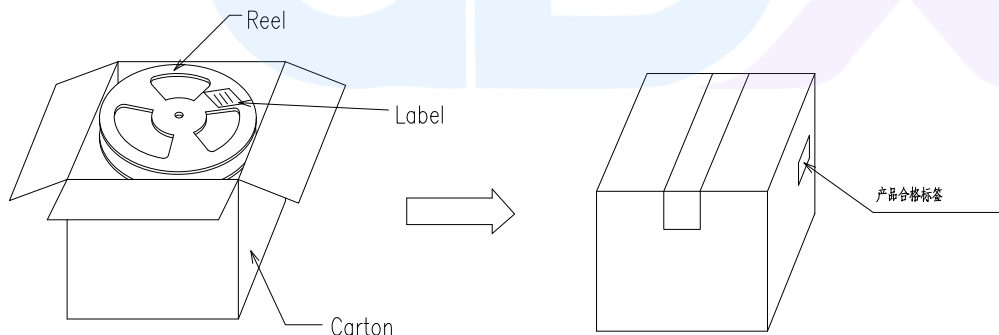
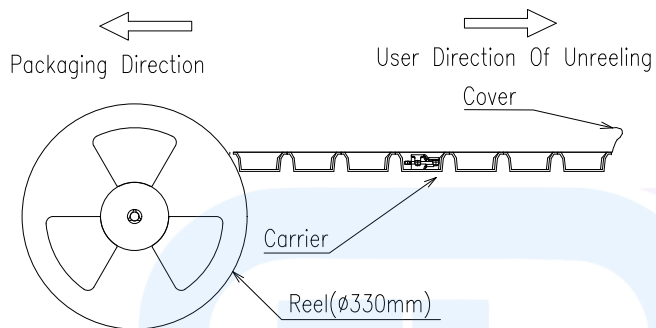
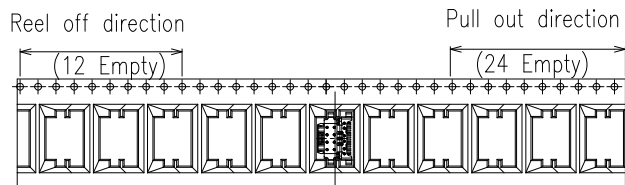

- NOTES:
1. 载带材质: PET 透明
2. 包装内容: SEE TABLE A

TABLE A :

PART NAME	PART NUMBER	PCS/ REEL	REEL/CARTON	QTY/CARTON	CARTON SIZE/MM
TYPE C 16PIN	X159	1500	10 REEL	15000 PCS	340*340*300

广东小迈实业有限公司

Website:

<https://www.xmconn.com>

TEL:

18938295888



PART NAME

USB Type-C 母 16pin 沉板1.58mm
舌片外露1.50mm 四脚防水型

PART NO.

DM68010-16FBAP-A

TOLERANCE UNLESS
OTHERWISE SPECIFIED:

X ±0.2
X.X ±0.15
X.XX ±0.10
X.XXX ±0.050

DRAWING:

Li

DATE:

2023.08.18

SCALE

SHEET

REV: A0

CHECK:

Chen

DATE:

2023.08.18

1:1

1/1

SIZE: A4

APPROVAL:

Wen

DATE:

2023.08.18

