

RoHS  
Compliant

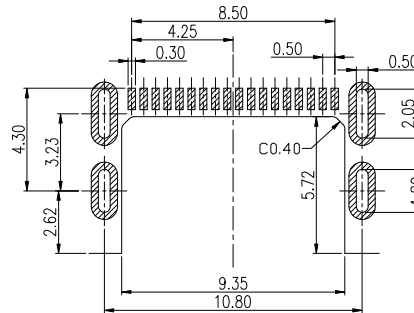
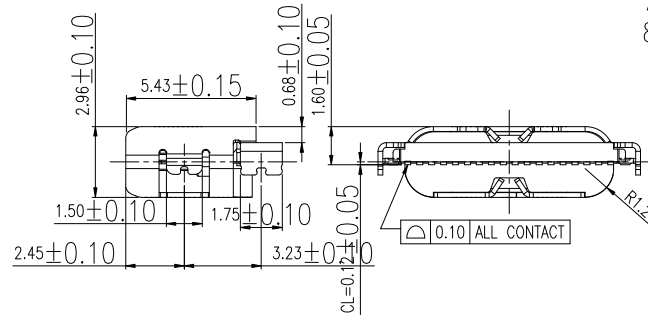
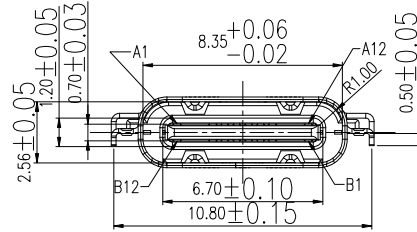
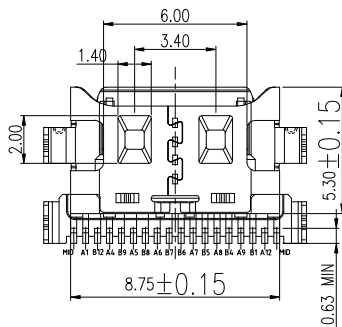
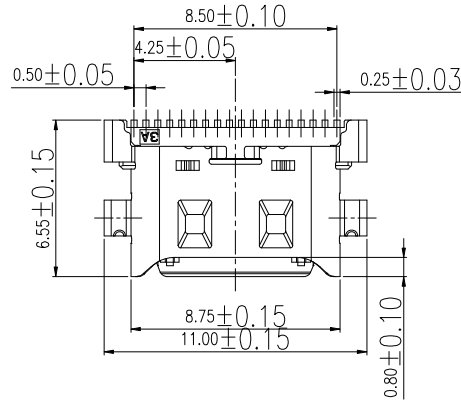
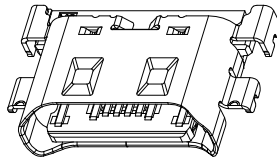

RECOMMENDED P.C.B. LAYOUT  
TOLERANCE UNSPECIFIED ±0.05mm

NOTES:

SPECIFICATION:

1. CURRENT RATING: 3.0A MAX
2. VOLTAGE: 100 VAC
3. TEMPERATURE RANGE: -30 °C ~ 85 °C
4. CONTACT RESISTANCE: 40 MILLIONHM MAX
5. INSULATION RESISTANCE: 100 MEGOHMS MIN.
6. INSERTION FORCE : 5N~20N
7. UNMATING FORCE: 8N~20N
8. DURABILITY: 10,000 CYCLES

Pin	Name	Pin	Name
A1	GND	B12	GND
	SSTXp1		SSRXp1
	SSTXn1		SSRXn1
A4	VBUS	B9	VBUS
A5	CC1	B8	SBU2
A6	Dp1	B7	Dn2
A7	Dn1	B6	Dp2
A8	SBU1	B5	CC2
A9	VBUS	B4	VBUS
	SSRXn2		SSTXn2
	SSRXp2		SSTXp2
A12	GND	B1	GND

7	SHELL	SUS304	Ni Plated	1PCS
6	OVER MOLDING	LCP&PA9T	BLACK	1PCS
5	TOP I/M	LCP&PA9T	BLACK	1PCS
4	BOTTOM I/M	LCP&PA9T	BLACK	1PCS
3	MID PLATE	SUS301	Ti/Ni Plated	1PCS
2	CONTACT	C7025&BRASS	Au/Ni Plated	1SET
1	CONTACT	C7025&BRASS	Au/Ni Plated	1SET
NO.	DESCRIPTION	MATERIAL	REMARKS	QTY

广东小迈实业有限公司

Website:

<https://www.xmconn.com>

TEL:

18938295888

**GDXM**®

PART NAME

USB C TYPE 16PIN REC. CL=0.12mm

PART NO.

DM18005-16FBAP-A

TOLERANCE UNLESS  
OTHERWISE SPECIFIED:

X ±0.2  
X.X ±0.15  
X.XX ±0.10  
X.XXX ±0.050

DRAWING:

Li

DATE:

2023.08.18

CHECK:

Chen

DATE:

2023.08.18

APPROVAL:

Wen

DATE:

2023.08.18

SCALE

1:1

SHEET

1/2

REV: A0

SIZE: A4



