

RoHS
Compliant

ZONE	ECN.N.O.	DESCRIPTION	DRAWING	DATE
A		INITIAL	林生財	20240531

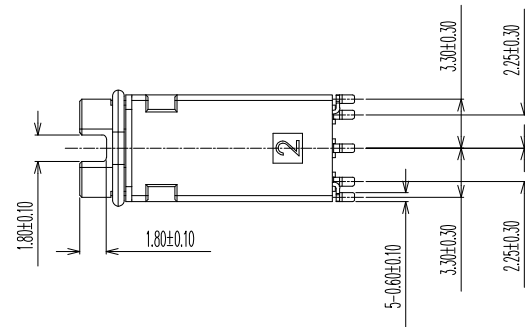

- NOTES
- CURRENT RATING: 1A.
 - CONTACT RESISTANCE: 50mΩ MAX.
 - INSULATION RESISTANCE: 100MΩ MIN.
 - DIELECTRIC WITHSTANDING: 500V AC MIN.
 - DURABILITY: 5000 CYCLES MIN.
 - CONNECTOR MATING FORCES: 3~30N.
 - CONNECTOR UNMATING FORCES: 3~30N.
 - OPERATING TEMPERATURE: -25°C TO +85°C.
 - WATERPROOF LEVEL: IP68

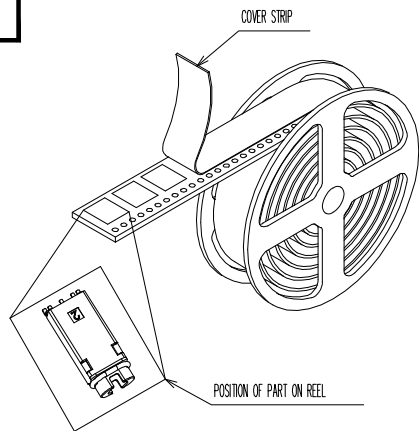
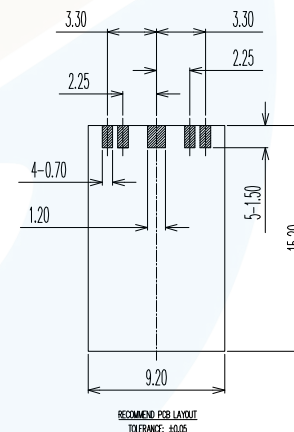
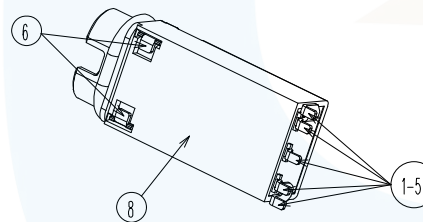
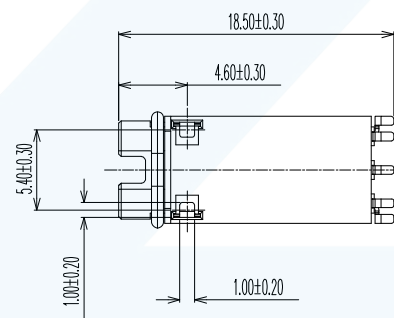
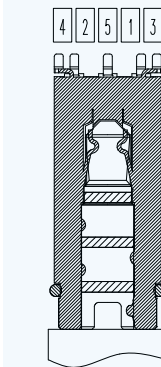
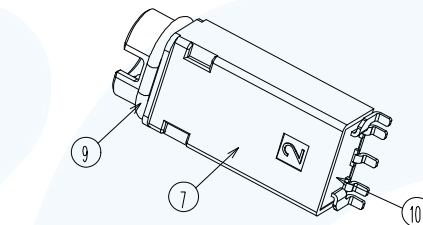
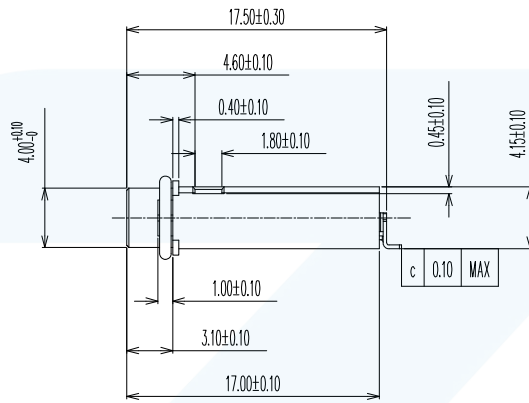
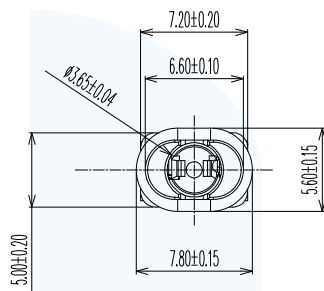

10	GLUE	1	EPOXY RESIN ADHESIVE	BLACK (SL407-DN)
9	O-RING	1	SILICONE RUBBER Ø0.8	RED
8	COVER	1	PA9T-G1350H, UL 94V-0	BLACK
7	HOUSING	1	PA9T G1350H, UL 94V-0	BLACK
6	TERMINAL 6#(HOLD DOWN)	2	C5210-EH, 0.25T	ALL OVER NICKEL 50u* MIN
5	TERMINAL 5#(TIP SPRING)	1	C5210-EH, 0.25T	ALL OVER 50u* Ni, Au 2u* MIN ON CONTACT AREA, Au 1u* MIN ON SOLDER AREA
4	TERMINAL 4#(RING SPRING)	1	C5210-EH, 0.25T	ALL OVER 50u* Ni, Au 2u* MIN ON CONTACT AREA, Au 1u* MIN ON SOLDER AREA
3	TERMINAL 3#(SLEEVE SPRING 3)	1	C5210-EH, 0.25T	ALL OVER 50u* Ni, Au 2u* MIN ON CONTACT AREA, Au 1u* MIN ON SOLDER AREA
2	TERMINAL 2#(SLEEVE SPRING 2)	1	C5210-EH, 0.25T	ALL OVER 50u* Ni, Au 2u* MIN ON CONTACT AREA, Au 1u* MIN ON SOLDER AREA
1	TERMINAL 1#(SLEEVE SPRING 1)	1	C5210-EH, 0.25T	ALL OVER 50u* Ni, Au 2u* MIN ON CONTACT AREA, Au 1u* MIN ON SOLDER AREA
NO	DESCRIPTION	QTY	MATERIAL	PLATING & COLOR

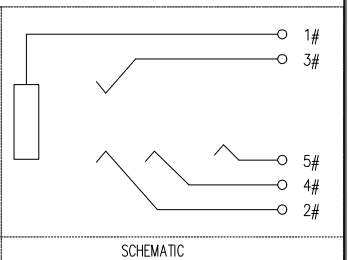
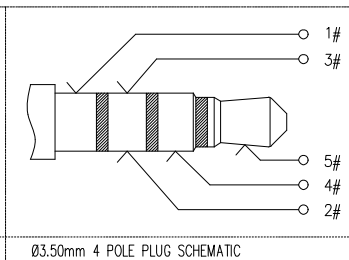
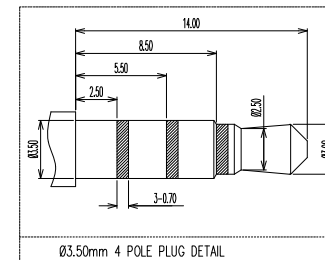

LZG INDUSTRIAL CO. LTD

DRAWING:	林生財	DATE:	20240531	SCALE	1:1
CHECK:	李宏鑫	DATE:	20240531	MATERIAL	*
APPROVAL:	楊進宝	DATE:	20240531	DWG. NO.	
DRAWING NO.				SHEET	1/1

PART NAME	Ø3.5 WATERPROOF JACK CONN	TOLERANCE UNLESS OTHERWISE SPECIFIED:	0.0±0.25 0.00±0.15 0.000±0.10	0.*±2° 0.0°±1° 0.00°±0.5°	UNIT: mm	
PART NO.	ZB23032-06SBAP-A					