

RoHS
Compliant

ZONE	E C N . N O .	DESCRIPTION	DRAWING	DATE
A		INITIAL	林生财	2023.11.24

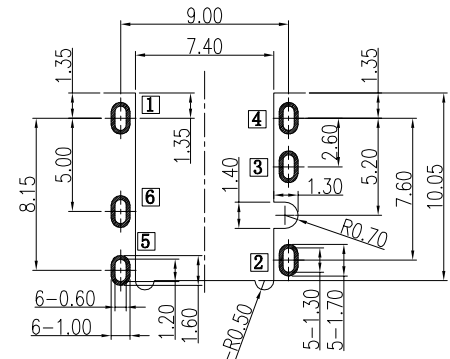
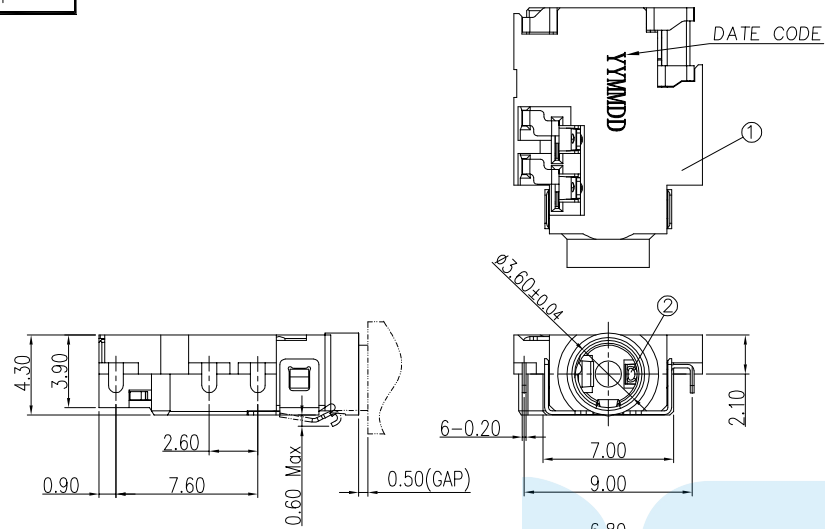

RECOMMENDED P.C.B LAYOUT
TOP VIEW (TOLRANCE:±0.05)

DATE CODE:

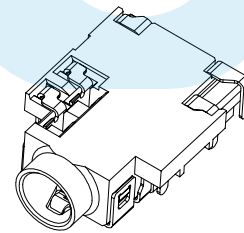
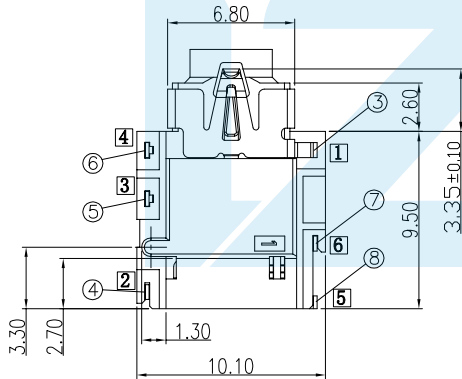
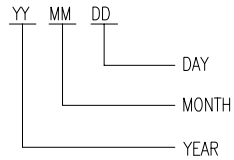

3D VIEW

NOTES:

- MATERIAL: SEE "TABLE 1";
- FINISH: SEE "TABLE 1";
- ELECTRICAL:
 - VOLTAGE RATING: 12 VAC RMS;
 - CURRENT RATING: 1.0 AMP;
 - CONTACT RESISTANCE: 50mΩ Max.(Initial), 100mΩ Max.(After Life test);
 - INSULATION RESISTANCE: 100 MΩ Min., 500VDC.(Initial), 50 MΩ Min., 500VDC.(After Humidity test);
 - WITHSTAND VOLTAGE: 500 VAC RMS 50(60)Hz, 1 minute;
- MECHANICAL:
 - MATING FORCE: 0.5-2.2Kgf.(Initial); 0.4-2.2Kgf.(After Life test);
 - UNMATING FORCE: 0.5-2.0Kgf.(Initial); 0.4-2.0Kgf.(After Life test);
 - OPERATING LIFE: 5000 CYCLES MIN.;
- ENVIRONMENTAL:
 - SALT SPRAY: 48H.
 - OPERATION: -30°C~+80°C.

TABLE 1:

NO.	PART NAME	QTY	MATERIAL	DESCRIPTION	REMARK
⑧	Contact_5	1	Phosphor bronze	Au 1u"Min	T=0.20mm
⑦	Contact_6	1	Phosphor bronze	Au 1u"Min	T=0.20mm
⑥	Contact_4	1	Phosphor bronze	Au 1u"Min	T=0.20mm
⑤	Contact_3	1	Phosphor bronze	Au 1u"Min	T=0.20mm
④	Contact_2	1	Phosphor bronze	Au 1u"Min	T=0.20mm
③	Contact_1	1	Phosphor bronze	Au 1u"Min	T=0.20mm
②	Separator	1	HIGH TEMP. PLASTIC	Black	
①	Housing	1	PA10T	Black	

PLUG SPEC

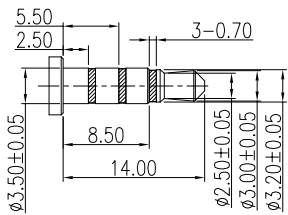

SCHEMATIC

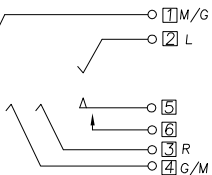

AFTER INSERT SCHEMATIC

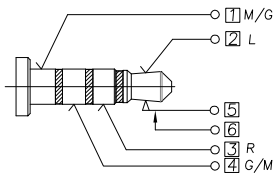

LZG INDUSTRIAL CO. LTD

PART NAME	ø3.50mm AUDIO JACK	TOLERANCE UNLESS	0.0±0.25	0.°±2°	UNIT: mm	APPROVAL:	杨进宝	DATE:	2023.11.24	SCALE	1:1
PART NO.	ZB23028-06FBAP-A	OTHERWISE SPECIFIED:	0.00±0.15	0.0°±1°							
			0.000±0.05	0.00°±0.5°		DRAWING NO.	ZB23028-06FBAP-A	SHEET	1/2		

DRAWING:	林生财	DATE:	2023.11.24	SCALE	1:1
CHECK:	李宏鑫	DATE:	2023.11.24	MATERIAL	*
DRAWING NO.	ZB23028-06FBAP-A	DWG. NO.			

RoHS
Compliant

ZONE	E C N . N O .	DESCRIPTION	DRAWING	DATE
A		INITIAL	林生财	2023.11.24

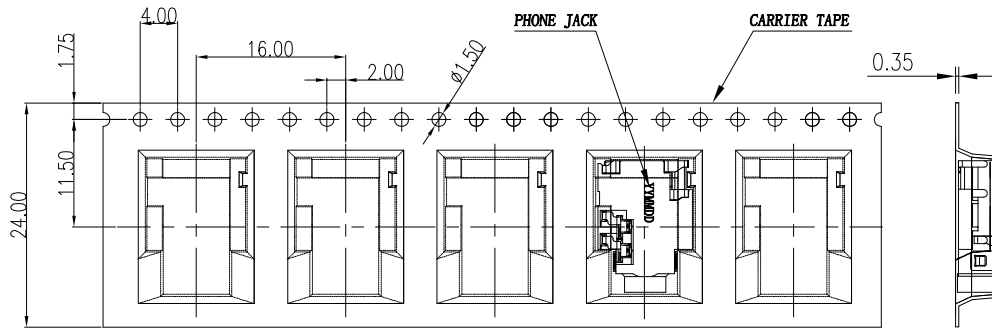
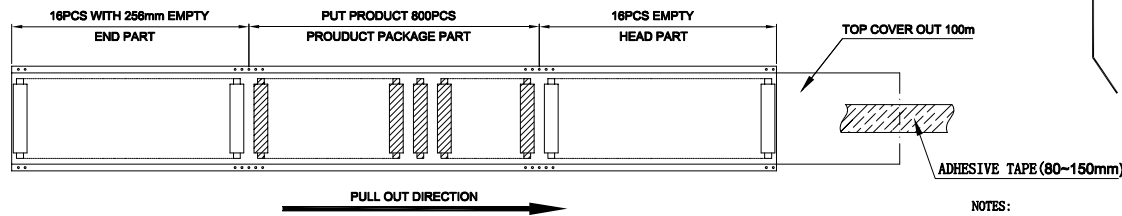
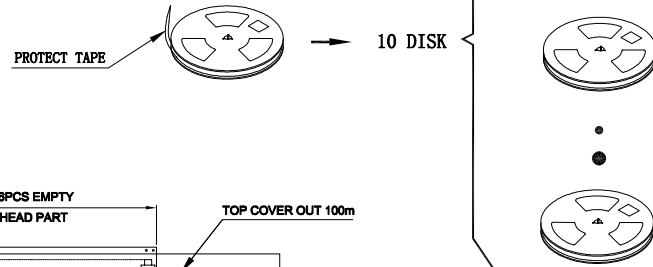
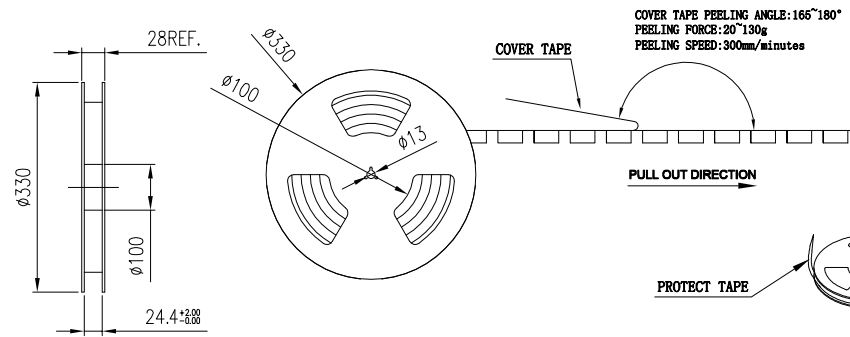

- NOTES:
- Material requirements:
 - The carton material requirements for the B-B, Dimension is 350*340*310mm;
 - Reel materials for FS; size reel for 330*28.
 - Packaging requirements:
 - The tape into the packing machine, before the empty 16PCS, after the release of the product 800PCS, then the empty 16PCS with 256mm length of stay;
 - Top cover should out 100mm of the carrier tape. After winding, using adhesive tape(80-150mm) to stick the leader of cover tap on the side of the carrier tape;
 - Winding a protect tape around the reel, then stick it by adhesive tape;
 - Label should paste in the designated area of the label;
 - Put a dryer and a packed reel in the vacuum bag and make the vacuum process;
 - The tired folded 10 disks in the carton total 8000pcs;
 - Packed finished packing sealing, and in the outer carton label

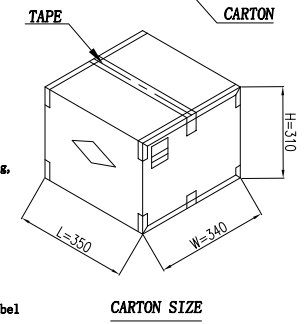
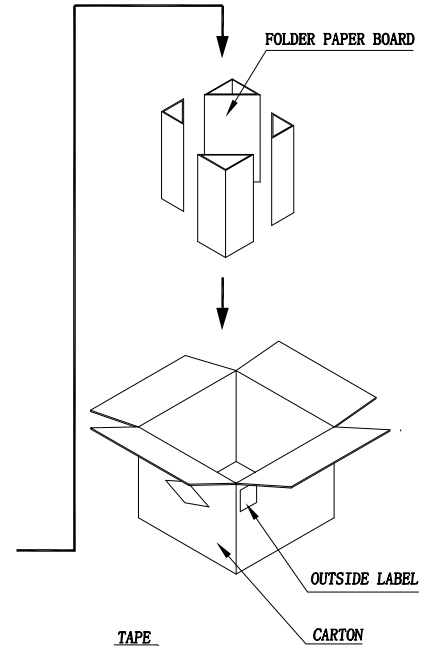

LZG INDUSTRIAL CO. LTD

PART NAME	ø3.50mm AUDIO JACK	TOLERANCE UNLESS	0.0±0.25	0.°±2°	UNIT:
PART NO.	ZB23028-06FBAP-A	OTHERWISE SPECIFIED:	0.00±0.15 0.000±0.05	0.0°±1° 0.00°±0.5°	

DRAWING:	林生财	DATE:	2023.11.24	SCALE	1:1
CHECK:	李宏鑫	DATE:	2023.11.24	MATERIAL	*
APPROVAL:	杨进宝	DATE:	2023.11.24	DWG. NO.	
DRAWING NO.	ZB23028-06FBAP-A			SHEET	2/2