

RoHS
Compliant

ZONE	E C N . N O .	DESCRIPTION	DRAWING	DATE
A		INITIAL	林生财	2020.02.18

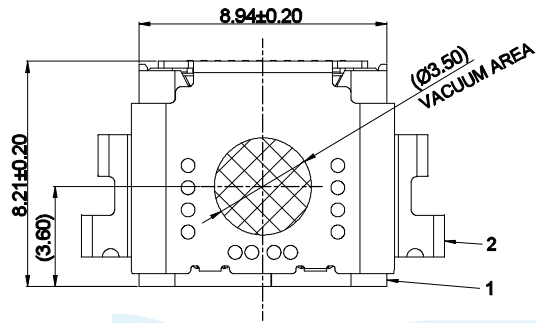

NOTE/注释:

1. SPECIFICATION/规格:

- 1.1 Rated current (额定电流): 5.0 A
- 1.2 Voltage rating (额定电压): 5V AC
- 1.3 Contact Resistance (接触阻抗): 40 mΩ Max.
- 1.4 Insulation Resistance (绝缘阻抗): 100MΩ Min.
- 1.5 Withstanding voltage (耐电压): 100 VAC/minute
- 1.6 Mating force (插入力): 5~20N.
- 1.7 Unmating force (拔出力): 8~20N.
- 1.8 Durability Cycle(寿命循环): 10,000 cycle
- 1.9 Operating temperature (工作温度): -40°~+85°

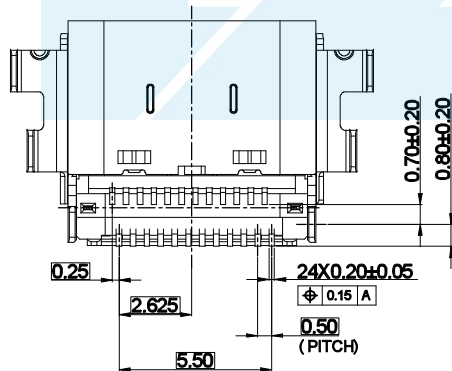
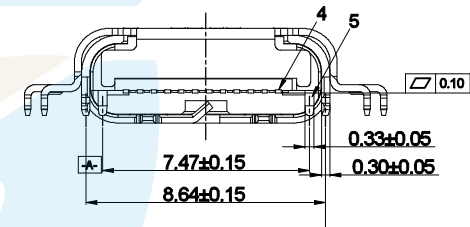
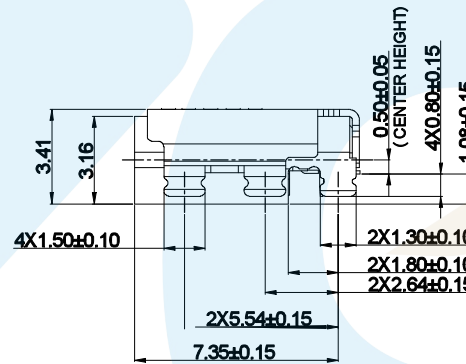
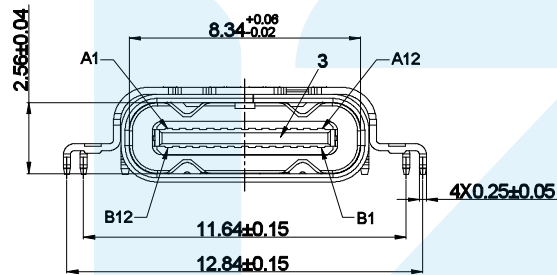

NO.	DESCRIPTION	MATERIAL	REMARKS	QTY
5	MID PLATE	Stainless Steel, T=0.15	NICKEL UNDER PLATED OVER ALL.	1
4	TERMINAL	COPPER ALLOY, T=0.12	MATING SIDE:Gold Plating; SOLDER TAIL:Gold FLASH, 50u" NICKEL OVERALL.	24
3	MAIN HOUSING	HIGH TEMPERATURE	COLOR BLACK UL94V-0	1
2	OUT SHELL	Stainless Steel, T=0.25	NICKEL UNDER PLATED OVER ALL.	1
1	MAIN SHELL	Stainless Steel, T=0.30	NICKEL UNDER PLATED OVER ALL.	1



LZG INDUSTRIAL CO. LTD

DRAWING:	林生财	DATE:	2020.02.18	SCALE	1:1
CHECK:	李宏鑫	DATE:	2020.02.18	MATERIAL	*
APPROVAL:	杨进宝	DATE:	2020.02.18	DWG. NO.	
DRAWING NO.	ZB48057-24SBAP-A			SHEET	1/2

PART NAME	TYPE C 24 PIN	TOLERANCE UNLESS	0.0±0.25	0.°±2°	UNIT:	mm
PART NO.	ZB48057-24SBAP-A	OTHERWISE SPECIFIED:	0.00±0.20 0.000±0.15	0.0°±1° 0.00°±0.5°		

RoHS
Compliant

ZONE	EC N. NO.	DESCRIPTION	DRAWING	DATE
A		INITIAL	林生财	2020.02.18

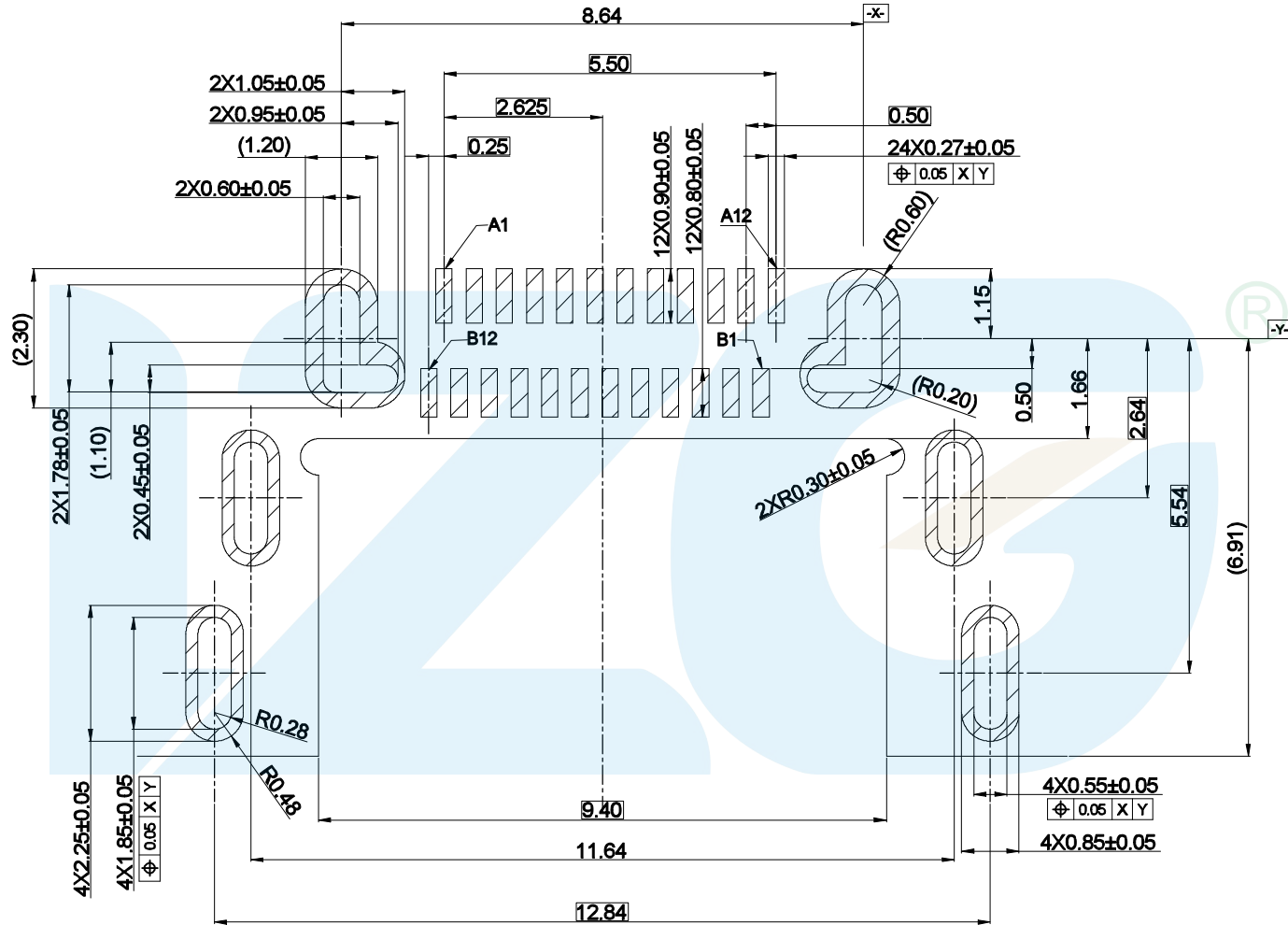

LZG INDUSTRIAL CO. LTD

PART NAME		TYPE C 24 PIN		TOLERANCE UNLESS		0.0±0.25		0.°±2°		DRAWING:		林生财		DATE:		2020.02.18		SCALE		1:1	
PART NO.		ZB48057-24SBAP-A		OTHERWISE SPECIFIED:		0.00±0.20		0.0°±1°		CHECK:		李宏鑫		DATE:		2020.02.18		MATERIAL		*	
						0.000±0.15		0.00°±0.5°		APPROVAL:		杨进宝		DATE:		2020.02.18		DWG. NO.			
										DRAWING NO.		ZB48057-24SBAP-A		SHEET		2/2					

