

RoHS
Compliant

ZONE	E.C.N.N.O.	DESCRIPTION	DRAWING	DATE
A		INITIAL	林生财	2020.02.18

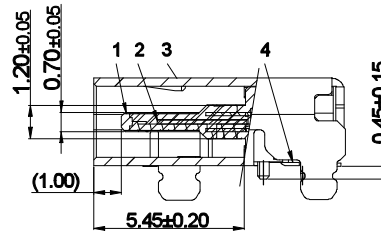
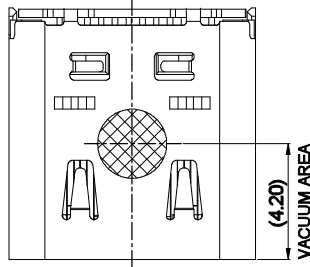

Section A-A

NOTE/注释:

1. SPECIFICATION/规格:

- 1.1 Rated current (额定电流): 5.0 A
- 1.2 Voltage rating (额定电压): 5V AC
- 1.3 Contact Resistance (接触阻抗): 40 m Ω Max.
- 1.4 Insulation Resistance (绝缘阻抗): 100MΩ Min.
- 1.5 Withstanding voltage (耐电压): 100 VAC/minute
- 1.6 Mating force (插入力): 5~20N.
- 1.7 Unmating force (拔出力): 8~20N.
- 1.8 Durability Cycle(寿命循环): 10,000 cycle
- 1.9 Operating temperature (工作温度): -40°~+85°

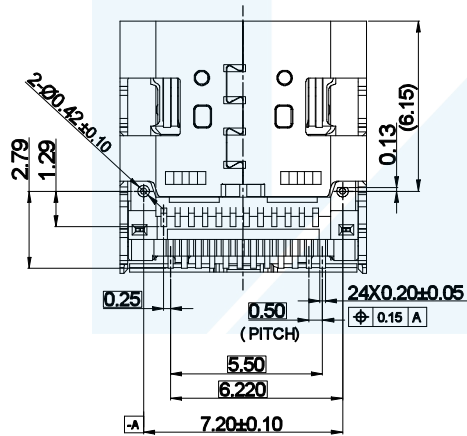
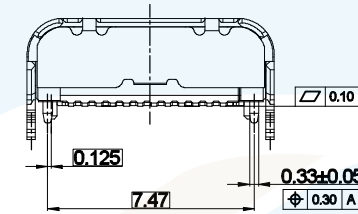
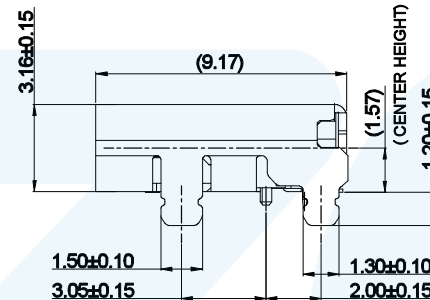
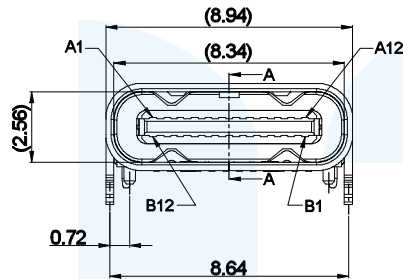

PIN ASSIGNMENT:

A1	A2	A3	A4	A5	A6	A7	A8	A9	A10	A11	A12
GND	TX1+	TX1-	Vbus	CC1	D+	D-	SBU1	Vbus	RX2-	RX2+	GND
GND	RX1+	RX1-	Vbus	SBU2	D-	D+	CC2	Vbus	TX2-	TX2+	GND
B12	B11	B10	B9	B8	B7	B6	B5	B4	B3	B2	B1

4	TERMINAL	COPPER ALLOY, T=0.12	MATING SIDE:Gold Plating; SOLDER TAIL:Gold FLASH, 50u" NICKEL OVERALL.	24
3	SHELL	Stainless Steel, T=0.30	NICKEL UNDER PLATED OVER ALL.	1
2	MID PLATE	Stainless Steel, T=0.15	NICKEL UNDER PLATED OVER ALL.	1
1	MAIN HOUSING	HIGH TEMPERATURE	COLOR BLACK 94V-0	1
NO.	DESCRIPTION	MATERIAL	REMARKS	QTY



LZG INDUSTRIAL CO. LTD

DRAWING:	林生财	DATE:	2020.02.18	SCALE	1:1
CHECK:	李宏鑫	DATE:	2020.02.18	MATERIAL	*
APPROVAL:	杨进宝	DATE:	2020.02.18	DWG. NO.	
DRAWING NO.	ZB48055-24DBAP-A			SHEET	1/2

PART NAME	TYPE C 24 PIN	TOLERANCE UNLESS	0.0±0.25	0.°±2°	UNIT:	mm
PART NO.	ZB48055-24DBAP-A	OTHERWISE SPECIFIED:	0.00±0.20	0.0°±1°		
			0.000±0.15	0.00°±0.5°		

RoHS
Compliant

ZONE	E.C.N. NO.	DESCRIPTION	DRAWING	DATE
A		INITIAL	林生财	2020.02.18

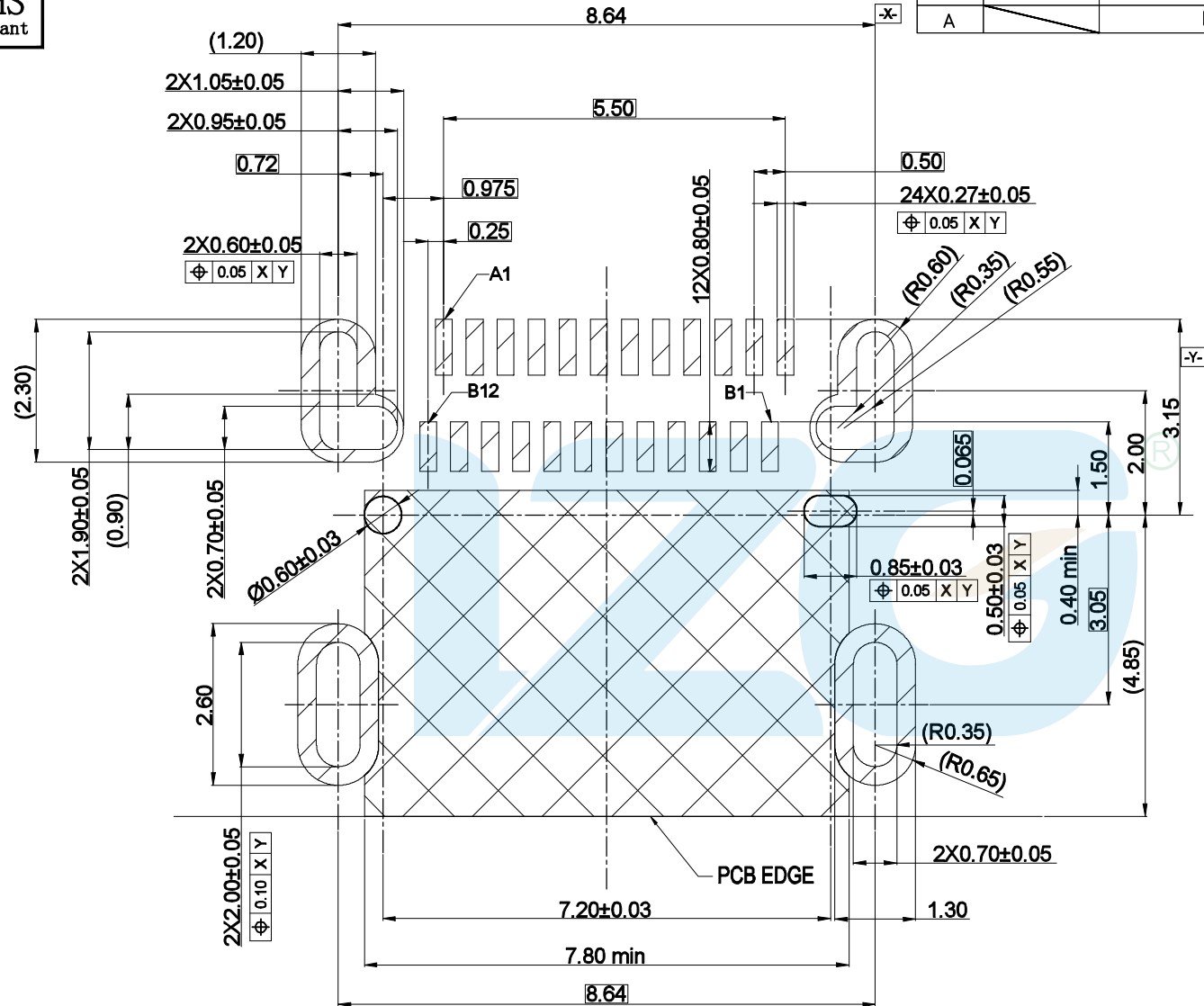

LZG INDUSTRIAL CO. LTD

DRAWING:	林生财	DATE:	2020.02.18	SCALE:	1:1
CHECK:	李宏鑫	DATE:	2020.02.18	MATERIAL:	*
APPROVAL:	杨进宝	DATE:	2020.02.18	DWG. NO.:	
DRAWING NO.:	ZB48055-24DBAP-A			SHEET:	2/2

PART NAME	TYPE C 24 PIN	TOLERANCE UNLESS	0.0±0.25	0.°±2°	UNIT:
PART NO.	ZB48055-24DBAP-A	OTHERWISE SPECIFIED:	0.00±0.20	0.0°±1°	
			0.000±0.15	0.00°±0.5°	