

RoHS  
Compliant

ZONE	EC.N.O.	DESCRIPTION	DRAWING	DATE
A		INITIAL	林生财	2020.02.18

NOTE/注释:

1. SPECIFICATION/规格:

- 1.1 Rated current (额定电流): 5.0 A For Vbus pin  
1.25A For Vconn pin  
0.25A For Other pin
- 1.2 Voltage rating (额定电压): 5V AC
- 1.3 Contact Resistance (接触阻抗): 40 m Ω Max.
- 1.4 Insulation Resistance (绝缘阻抗): 100MΩ Min.
- 1.5 Withstanding voltage (耐电压): 100 VAC/minute
- 1.6 Mating force (插入力): 5~20N .
- 1.7 Unmating force (拔出力): 8~20N.
- 1.8 Durability Cycle(寿命循环): 10,000 cycle
- 1.9 Operating temperature (工作温度): -40~+85°

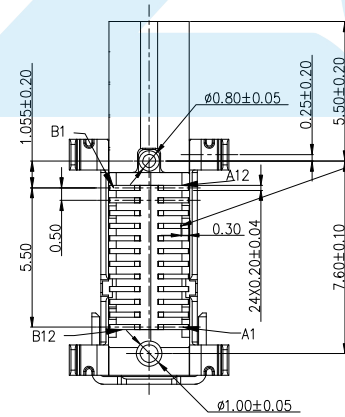
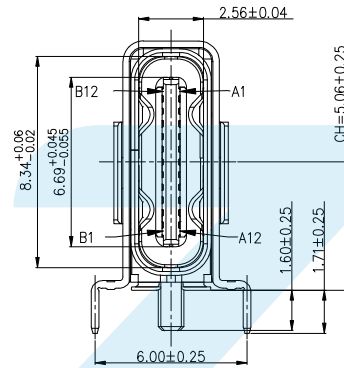
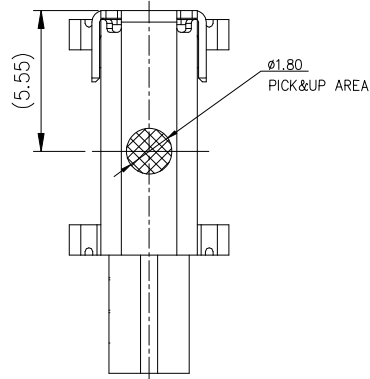
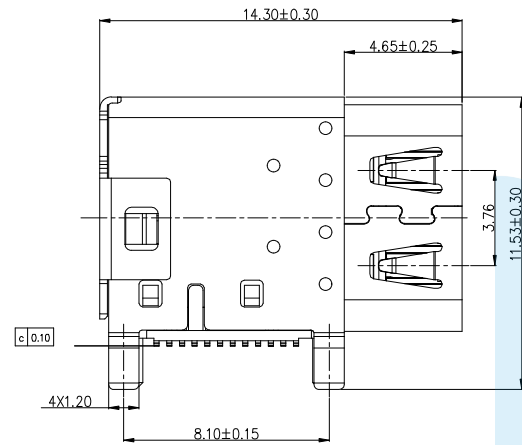

焊接区金/G/F  
测点位置

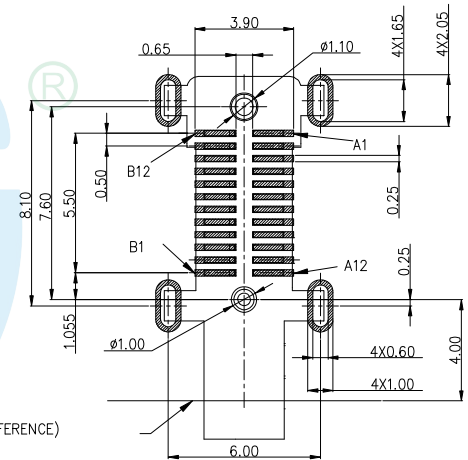

(PCB EDGE REFERENCE)

RECOMMENDED P.C.B LAYOUT  
TOLERANCE ± 0.05mm (TOP VIEW)

5	TERMINAL	COPPER ALLOY T=0.12	MATING SIDE: GOLD PLATING SOLDER TAIL: G/F, 50μ" NICKEL OVERALL.	24
4	OUT SHELL	SUS304 T=0.30	50μ" NICKEL PLATING	1
3	INNER SHELL	SUS304 T=0.30	50μ" NICKEL PLATING	1
2	MID PLATE	SUS301 T=0.15	30μ" NICKEL PLATING	1
1	MAIN HOUSING	HIGH TEMPERATURE	LOP BLACK UL94V-0	1
NO.	DESCRIPTION	MATERIAL	REMARKS	QTY

**LZG** LZG INDUSTRIAL CO. LTD

DRAWING:	林生财	DATE:	2020.02.18	SCALE	1:1
CHECK:	李宏鑫	DATE:	2020.02.18	MATERIAL	*
APPROVAL:	杨进宝	DATE:	2020.02.18	DWG. NO.	
DRAWING NO.	ZB48053-24DBAP-A			SHEET	1/1

PART NAME	TYPE C 24 PIN	TOLERANCE UNLESS	0.0±0.3	0.1±2°	UNIT: mm	
PART NO.	ZB48053-24DBAP-A	OTHERWISE SPECIFIED:	0.00±0.2 0.000±0.1	0.0°±1° 0.00°±0.5°		