

RoHS
Compliant

| ZONE | E C N . N O . | DESCRIPTION | DRAWING | DATE |
|------|---------------|-------------|---------|------------|
| A | | INITIAL | 林生财 | 2020.02.18 |

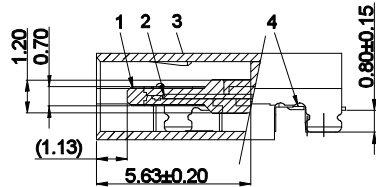
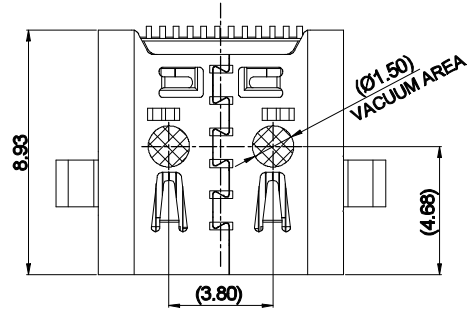

Section A-A

NOTE/注释:

1. SPECIFICATION/规格:

- 1.1 Rated current (额定电流): 5.0 A
- 1.2 Voltage rating (额定电压): 5V AC
- 1.3 Contact Resistance (接触阻抗): 40 mΩ Max.
- 1.4 Insulation Resistance (绝缘阻抗): 100MΩ Min.
- 1.5 Withstanding voltage (耐电压): 100 VAC/minute
- 1.6 Mating force (插入力): 5~20N.
- 1.7 Unmating force (拔出力): 8~20N.
- 1.8 Durability Cycle(寿命循环): 10,000 cycle
- 1.9 Operating temperature (工作温度): -40°~+85°

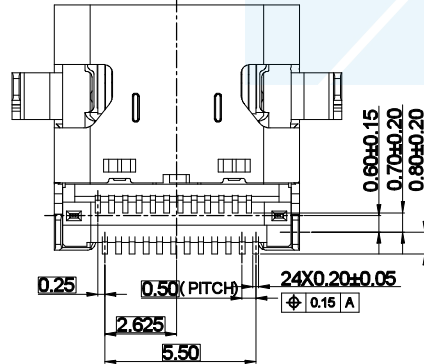
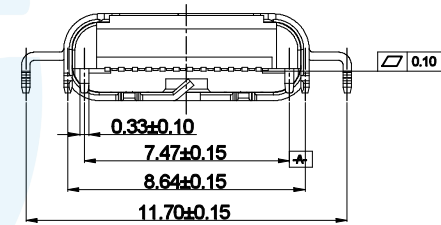
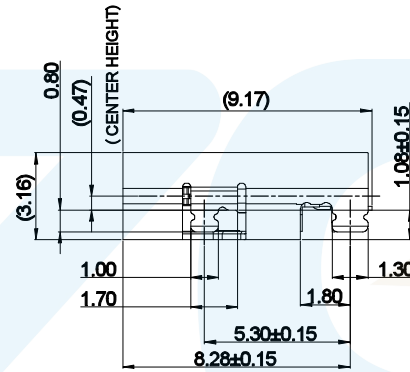
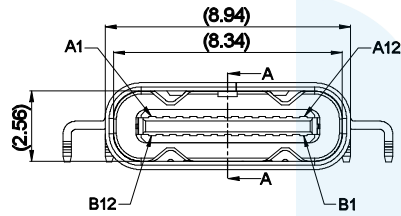

PIN ASSIGNMENT

| A1 | A2 | A3 | A4 | A5 | A6 | A7 | A8 | A9 | A10 | A11 | A12 |
|-----|------|------|------|------|----|----|------|------|------|------|-----|
| GND | TX1+ | TX1- | Vbus | CC1 | D+ | D- | SBU1 | Vbus | RX2- | RX2+ | GND |
| GND | RX1+ | RX1- | Vbus | SBU2 | D- | D+ | CC2 | Vbus | TX2- | TX2+ | GND |
| B12 | B11 | B10 | B9 | B8 | B7 | B6 | B5 | B4 | B3 | B2 | B1 |

| NO. | DESCRIPTION | MATERIAL | REMARKS | QTY |
|-----|--------------|-------------------------|--|-----|
| 4 | TERMINAL | COPPER ALLOY, T=0.12 | MATING SIDE:Gold Plating; SOLDER TAIL:Gold FLASH, 50u" NICKEL OVERALL. | 24 |
| 3 | SHELL | Stainless Steel, T=0.30 | NICKEL UNDER PLATED OVER ALL. | 1 |
| 2 | MID PLATE | Stainless Steel, T=0.15 | NICKEL UNDER PLATED OVER ALL. | 1 |
| 1 | MAIN HOUSING | HIGH TEMPERATURE | COLOR BLACK 94V-0 | 1 |



LZG INDUSTRIAL CO. LTD

| | | | | | |
|-------------|------------------|-------|------------|----------|-----|
| DRAWING: | 林生财 | DATE: | 2020.02.18 | SCALE | 1:1 |
| CHECK: | 李宏鑫 | DATE: | 2020.02.18 | MATERIAL | * |
| APPROVAL: | 杨进宝 | DATE: | 2020.02.18 | DWG. NO. | |
| DRAWING NO. | ZB48052-24FBAP-A | | | SHEET | 1/2 |

| | | | | | | |
|-----------|------------------|----------------------|------------|------------|-------|----|
| PART NAME | TYPE C 24 PIN | TOLERANCE UNLESS | 0.0±0.25 | 0.°±2° | UNIT: | mm |
| PART NO. | ZB48052-24FBAP-A | OTHERWISE SPECIFIED: | 0.00±0.20 | 0.0°±1° | | |
| | | | 0.000±0.15 | 0.00°±0.5° | | |

RoHS
Compliant

| ZONE | EC N. NO. | DESCRIPTION | DRAWING | DATE |
|------|-----------|-------------|---------|------------|
| A | | INITIAL | 林生财 | 2020.02.18 |

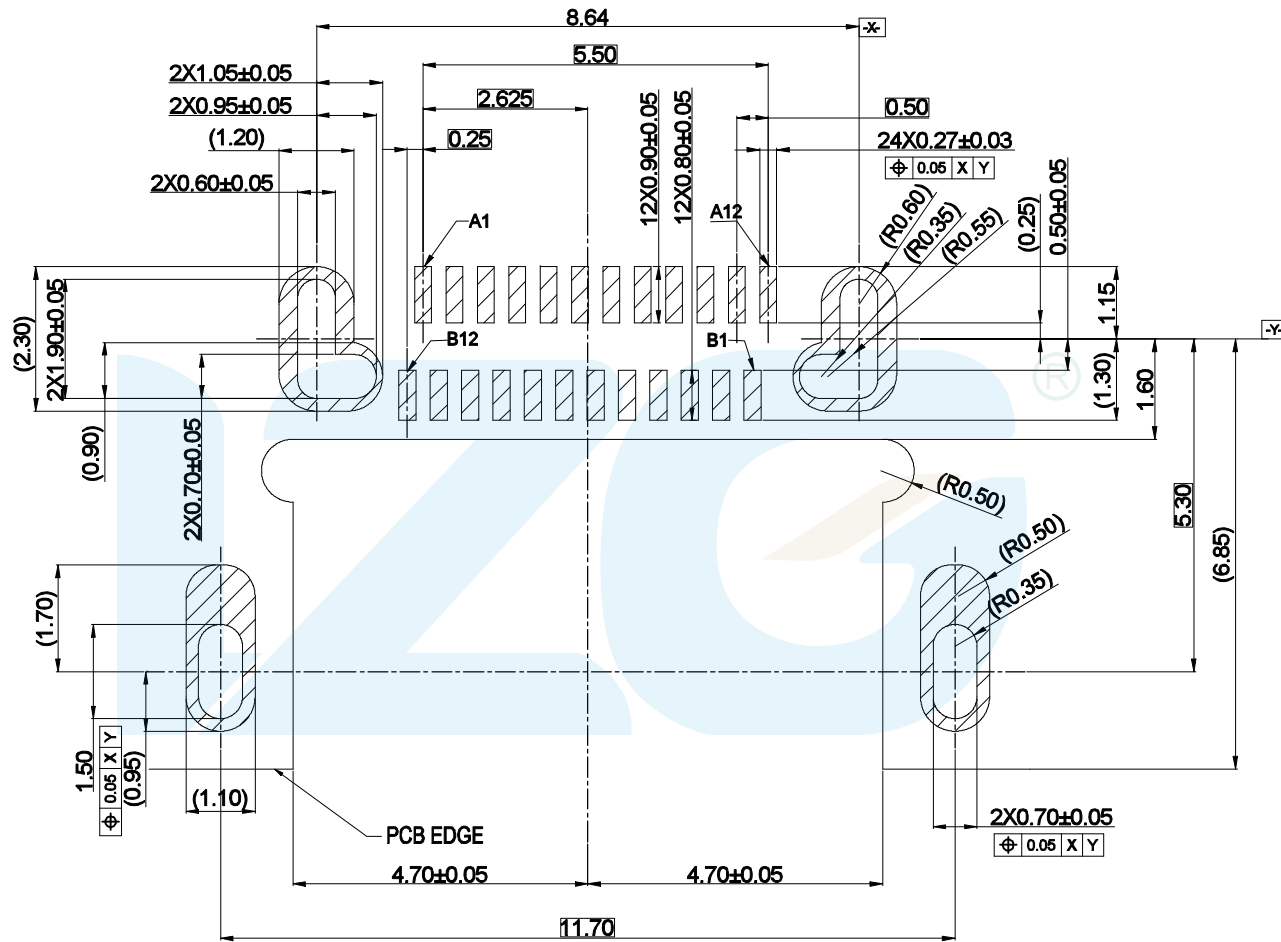

LZG INDUSTRIAL CO. LTD

| | | | | | |
|-----------|------------------|----------------------|-------------------------|-----------------------|-------|
| PART NAME | TYPE C 24 PIN | TOLERANCE UNLESS | 0.0±0.25 | 0.°±2° | UNIT: |
| PART NO. | ZB48052-24FBAP-A | OTHERWISE SPECIFIED: | 0.00±0.20 0.000±0.15 | 0.0°±1° 0.00°±0.5° | |

| | | | | | |
|-------------|------------------|-------|------------|----------|-----|
| DRAWING: | 林生财 | DATE: | 2020.02.18 | SCALE | 1:1 |
| CHECK: | 李宏鑫 | DATE: | 2020.02.18 | MATERIAL | * |
| APPROVAL: | 杨进宝 | DATE: | 2020.02.18 | DWG. NO. | |
| DRAWING NO. | ZB48052-24FBAP-A | | | SHEET | 2/2 |