

3D VIEW

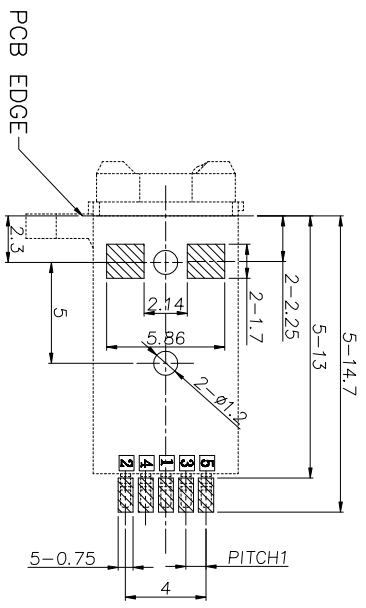

RECOMMENDED P.C.B LAYOUT
TOP VIEW (TOLERANCE:±0.05)

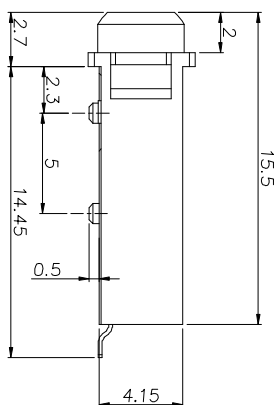
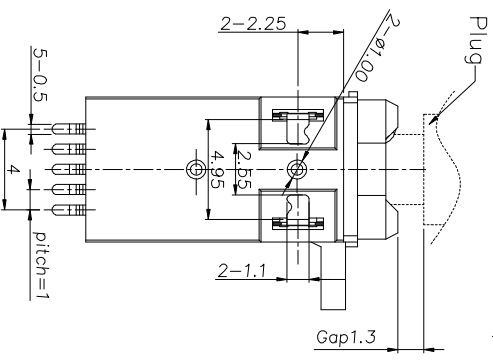
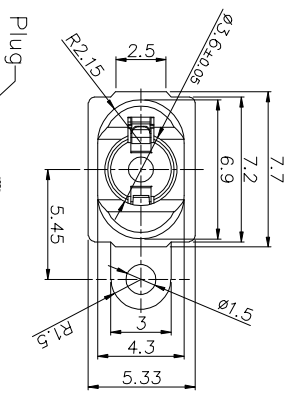

SPECIFICATION:

- Electrical characteristics
 - Current rating:DC 0.5A max.
 - Voltage rating:DC 30V.
 - Contact resistance:50mΩ max
 - Insulation resistance:1000MΩ min. at 500V DC.
 - Withstanding voltage:500V AC for 1 minute.
- Mechanical characteristics
 - Life test:5000 cycles min,
 - Mating force:3~30N,
Umating force:3~30N.
- Temperature range: -40°C~+80°C
- Dustproof and waterproof grade: IP67

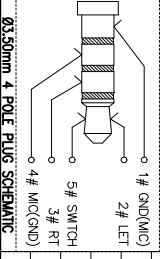
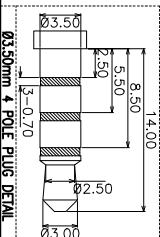

NO.	DESCRIPTION	MATERIAL	REMARKS	QTY
9	RUBBER RING	SILICA GEL	COLOR WHITE	1
8	COVER	HIGH TEMPERATURE	COLOR BLACK	1
7	HOUSING	HIGH TEMPERATURE	COLOR BLACK	1
6	SHUNT	PHOSPHOR BRONZE,0.15t	3.5TAL ON CONTACT AREA AND GOLD FLASH ON OTHER AREA.	2
5	TIP SPRING	PHOSPHOR BRONZE,0.20t	3.5TAL ON CONTACT AREA AND GOLD FLASH ON OTHER AREA.	1
4	RING SPRING	PHOSPHOR BRONZE,0.20t	3.5TAL ON CONTACT AREA AND GOLD FLASH ON OTHER AREA.	1
3	RING SPRING	PHOSPHOR BRONZE,0.20t	3.5TAL ON CONTACT AREA AND GOLD FLASH ON OTHER AREA.	1
2	TIP SPRING	PHOSPHOR BRONZE,0.20t	3.5TAL ON CONTACT AREA AND GOLD FLASH ON OTHER AREA.	1
1	EARTH SPRING	PHOSPHOR BRONZE,0.20t	3.5TAL ON CONTACT AREA AND GOLD FLASH ON OTHER AREA.	1

LZG INDUSTRIAL CO. LTD

WATERPROOF Ø3.5 PHONE JACK

TOLERANCE UNLESS OTHERWISE SPECIFIED: 0.00±0.13

0.0±0.38

0.0±0.25

0.0±0.1

0.00±0.5

UNIT: mm

0.5±0.2

0.0±0.1

0.00±0.5

DRAWING NO.	DATE	SCALE	SHEET
ZB23014-07SBAP-A	2020.02.18	1:1	1/1

WATERPROOF Ø3.5 PHONE JACK

TOLERANCE UNLESS OTHERWISE SPECIFIED: 0.00±0.13

0.0±0.38

0.0±0.25

0.0±0.1

0.00±0.5

UNIT: mm

0.5±0.2

0.0±0.1

0.00±0.5

LZG INDUSTRIAL CO. LTD

WATERPROOF Ø3.5 PHONE JACK

TOLERANCE UNLESS OTHERWISE SPECIFIED: 0.00±0.13

0.0±0.38

0.0±0.25

0.0±0.1

0.00±0.5

UNIT: mm

0.5±0.2

0.0±0.1

0.00±0.5

DRAWING NO.	DATE	SCALE	SHEET
ZB23014-07SBAP-A	2020.02.18	1:1	1/1