

ZONE	ECN. NO.	DESCRIPTION	DRAWING	DATE
A		INITIAL	林生财	2020.02.18

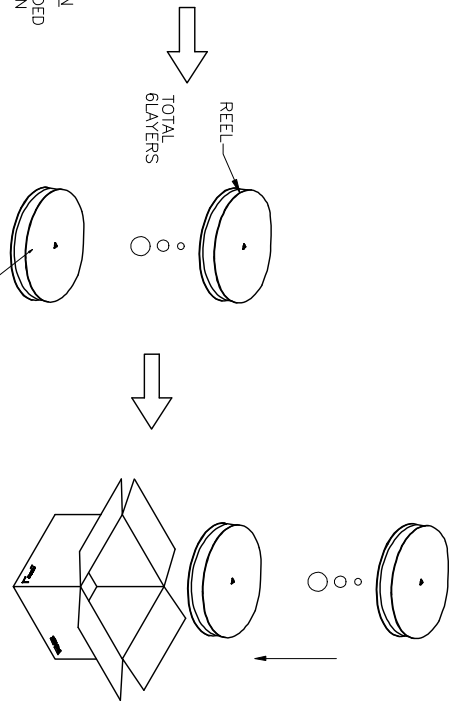
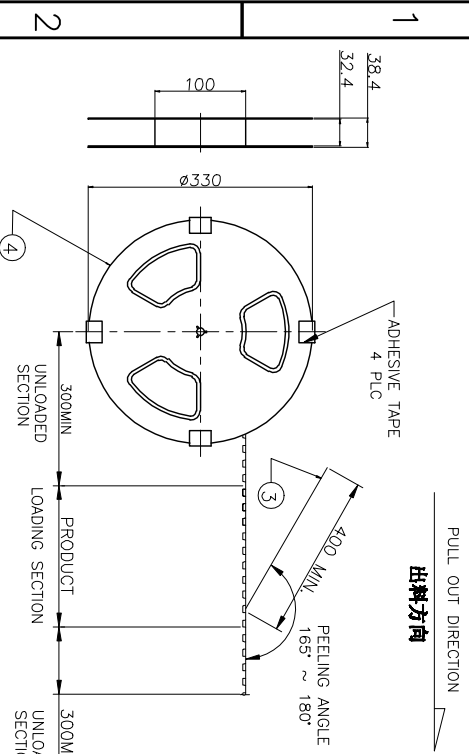

- 备注:
1. 包装方式
1-1: 使用半自动包装机, 先将 CARRY TAPE 送入卷轴中, 并与 COVER TAPE 贴合在上面, 其中前后至少300mm 空槽不要放产品, 然后将产品如图所示方向依次放入 CARRY TAPE 每个槽放1PCS;
 - 1.2. 用胶带将 CARRY TAPE 叠合在一起;
 - 1-3: 按图示要求将8盘包装好的REEL 套入防水袋后装入纸箱;
 - 1-4: 将装好产品的纸箱按图示要求封箱, 在指定区域贴好 LABEL;

2. 包装数量:
700PCS/REEL;
8REEL (5600PCS) / CARTON.

3. 耐刮属性:
上带引拉力测试规格: 20~1500gf
测试条件: 以每分钟 300mm 速度引拔测试

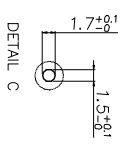
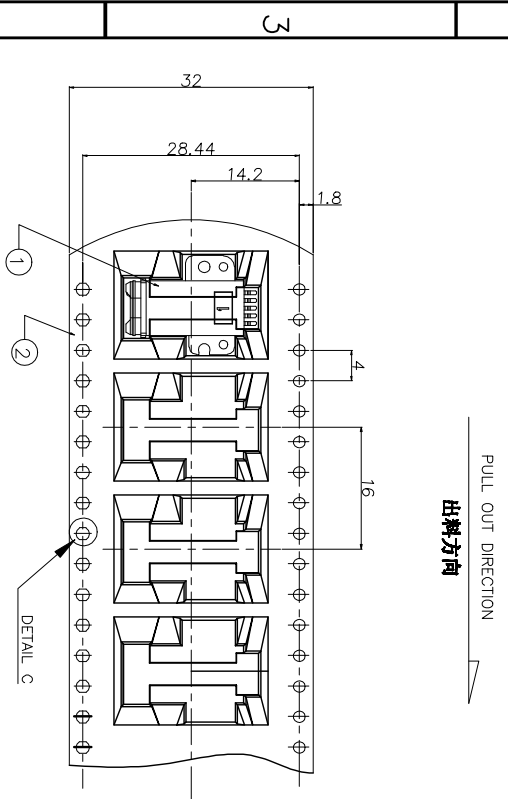

NO.	NAME	SPEC	Q'TY
7	标签	标签只贴在外箱	1PCS
6	防水袋	0.005*(50+40)*100(cm)	1PCS
5	外箱	L=350, W=350, H=270	1PCS
4	卷盘	PS,BLUE,A=330,B=100,W=38.4	6PCS
3	上带	PET,CLEAR,W=28.4	11.8m
2	胶带	PS,BLACK,W=32,T=0.4,P=16	11.8m
1	ø3.5mm PHONE JACK	ø3.5mm PHONE JACK	5600PCS

LZG INDUSTRIAL CO., LTD

WATERPROOF ø3.5 PHONE JACK

TOLERANCE UNLESS OTHERWISE SPECIFIED: 0.009±0.10

PART NO. ZB23010-07SBAP-A

0.0±0.25 0.00±0.15 0.0±0.2 0.0±0.1 0.00±0.5

UNIT: mm

DRAWING: 林生财 DATE: 2020.02.18 SCALE 1:1

CHECK: 李宏鑫 DATE: 2020.02.18 MATERIAL *

APPROVAL: 郭进宝 DATE: 2020.02.18 DWG. NO.

DRAWING NO. ZB23010 PACKING DRAWING SHEET 1/1